



VEMAVENTURI
A PERI COMPANY

INSITE CONSTRUCTION (ISC)

ISC Hub and Node

PREMO Concrete Pressure Monitoring

TEMO Concrete Temperature and Maturity Monitoring

PHONO Concrete Detection and Compaction Monitoring

User Manual v1.1



Language



English 4 – 44



French XX – XX



Spanish XX – XX



German XX – XX

Content

1 Overview 4

2 Introduction 5

- 2.1. Intended use 5
- 2.2. Instructions on use 5
- 2.3. Target groups 5

3 Safety Instructions 6

- 3.1. Warnings 6
- 3.2. General information 6

4 Initial Setup 7

- 4.1. InSite Construction WebApp 7

5 ISC Hub and Node 8

- 5.1. ISC Hub Technical details 8
- 5.2. ISC Node Technical details 9
- 5.3. Dimensions 10
- 5.4. Hub and Node Overview 11
- 5.5. Network Connectivity Overview 20
- 5.6. Changing the network mode 20
- 5.7. Mesh mode 21
- 5.8. Wi-Fi mode 22
- 5.9. Guide: Setting Up Nodes for Maximum Range 23
- 5.10. Disclaimers 23

6 System Operation 24

- 6.1. Commissioning the System 24

7 Maintenance and storage 25

8 Recycling and disposal 26

- 8.1. Disposal 26

9 Troubleshooting 27

- 9.1. ISC Hub and Node 27

10 LED Indicators Hub and Node 28

- 10.1. LED indicators Hub 28
- 10.2. LED indicators Node 29

11 System Peripherals 30

12 PREMO Concrete Pressure Monitoring 31

- 12.1. Technical details 31
- 12.2. Fitting and connecting the pressure sensor 32
- 12.3. Deinstallation 34
- 12.4. Troubleshooting 34
- 12.5. Maintenance 35

13 TEMO Concrete Temperature and Maturity Monitoring 38

- 13.1. Technical details 38
- 13.2. Calibration for Concrete Maturity Monitoring 38
- 13.3. Installation 40
- 13.4. Removal 41
- 13.5. Troubleshooting 41

14 PHONO Concrete Detection and Compaction Monitoring 42

- 14.1. Technical details 42
- 14.2. Attaching and connecting up the sensor 42
- 14.3. Checking the functional integrity 43
- 14.4. Deinstallation 44
- 14.5. Cleaning 44
- 14.6. Maintenance and repairs 44
- 14.7. Troubleshooting 44

1 Overview



- 1. LED indicators Hub
- 2. Ethernet / CAN connection
- 3. Analogue buttons
- 4. PERI Bus connection

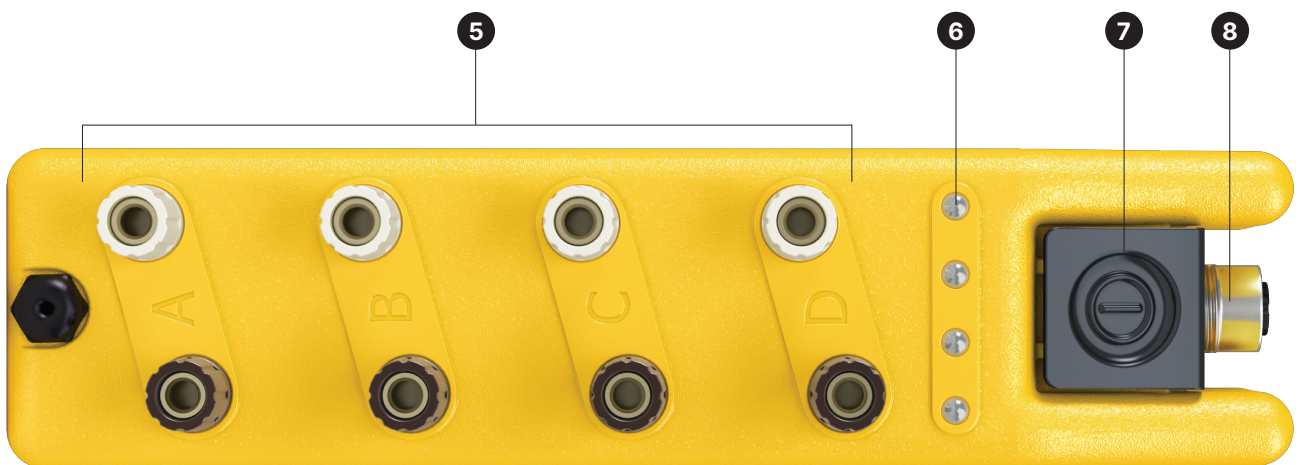

- 5. Temperature and vibration sensor connections
- 6. LED indicators Node
- 7. Analogue buttons
- 8. PERI Bus connection

2 Introduction

The InSite Construction System provides precise and user-friendly monitoring for your project. With a variety of sensors available for use with the central Hub, it enables measurement of parameters such as concrete pressure, temperature, and compaction. Data can be monitored in real time either directly on the Hub or remotely via our WebApp. All measured data is automatically uploaded to the cloud when connected via LTE or Wi-Fi. If the system loses connection, it stores data locally and uploads it once cloud access is restored.

2.1. Intended use

Vemaventuri products are designed solely for use in the industrial and commercial sectors by trained personnel.

Only use the product for its specified purpose, while strictly adhering to the provided technical data.

Any use outside the intended purpose is not allowed.

The function and operational safety of the product can only be guaranteed if the generally applicable safety precautions, national regulations, and the specific safety instructions in these Instructions for Use are followed.

The product is intended for measuring purposes as defined and outlined in the technical data. Only the instructions described in the Instructions for Use constitute proper use of the product.

The information regarding the intended use of the system must be observed.

2.2. Instructions on use

Usage that deviates from the intended use as outlined in the Instructions for Assembly and Use constitutes a misapplication with potential safety risks.

Changes to Vemaventuri components are not permitted.

Only original Vemaventuri parts may be used. The use of non-Vemaventuri products or spare parts constitutes misapplication with associated safety risks.

2.3. Target groups

Contractors

These Instructions for Use are intended for contractors who utilize Vemaventuri products for industrial tasks, including measuring or monitoring operations.

Construction site coordinator

The Safety and Health Protection Coordinator is appointed by the client and must:

- Identify potential hazards during the planning phase.
- Determine measures to mitigate risks.
- Create a health and safety plan.
- Coordinate protective measures for contractors and personnel, ensuring they do not endanger each other.
- Monitor compliance with safety measures.

Competent personnel

Competent personnel must possess specialist knowledge gained from professional training, work experience, and recent professional activity, allowing them to understand safety-related issues and carry out inspections properly. Depending on the complexity of the task, varying levels of specialist knowledge may be required.



In other countries, ensure compliance with relevant national guidelines and regulations. If no country-specific regulations are available, it is recommended to follow German guidelines and regulations.

Qualified persons

Vemaventuri products may only be used by personnel who are suitably qualified. These qualified individuals must receive instructions covering at least the following points:

- An understandable explanation of the assembly or dismantling plan for the Vemaventuri product.
- A description of the safety measures for assembling or dismantling the Vemaventuri product.
- Details on safety precautions for changing weather conditions that may impact the product's safety or the personnel.
- Information on permissible loads.

3 Safety Instructions

3.1. Warnings

Warnings appear before instructions for action and are categorised as follows:



Danger

means that serious bodily injury or death will occur if the aforementioned precautions are not taken.



Warning

means that serious bodily injury or death may occur if the aforementioned precautions are not taken.



Caution

means that minor bodily injury may occur if the aforementioned precautions are not taken.



means that damage to property or an undesirable situation may occur if the aforementioned precautions are not taken.

3.2. General information



Warning

If the equipment is used in a manner not specified by the manufacturer or this document, the protection provided by the equipment may be impaired.



Warning

The unit is only for indoor charging with the power adapter and is powered by an internal battery inside the unit when operated in outside environment.



Warning

Do not leave the unit exposed to direct sunlight for an extended period of time.



Safety instructions apply to all service life phases of the system.

The contractor must ensure that the installation and operating instructions provided are available at all times and understood by the site personnel.

3.2.1. Before using the system

- Read and understand this manual and the safety instructions it contains carefully.
- Observe the laws and regulations in force in the country of use. This includes, in particular, safety precautions as required when handling live equipment.
- Check units, mains cables and accessories for damage and functional correctness.
- Damaged connectors and cables must be removed immediately and no longer used.
- Only use original spare parts from the manufacturer.

Failure to observe these safety precautions may result in injury or damage to the unit.

The unit has been designed for use in harsh environments. Operations outside of the specified conditions may result in damage to the equipment.

3.2.2. Charging the unit



Danger

Lithium-ion battery is installed in the unit. The battery may only be replaced by a qualified person!

The usage time or the discharge speed of a battery depends on several factors:

- Ambient temperature
- Usage time with the screen ON
- Screen brightness
- Battery age

If the battery capacity and discharge time have decreased significantly, the battery should be replaced. To do this, contact a service workshop designated by the manufacturer.

Never replace the batteries yourself.

4 Initial Setup

In this chapter we will guide you through the initial setup of the system, we will go through:

- The InSite Construction WebApp – <https://insite.peri.app/>
- How to set up a project
- How to set up dashboards
- How to connect devices to your project
- How to add measurements

For more information about the different devices and sensors, please see the chapter associated with that device or sensor.

- PREMO Concrete pressure (Page 31)
- TEMO Concrete temperature and maturity (Page 36)
- PHONO Concrete detection and compaction (Page 38)

4.1. InSite Construction WebApp

With our ISC WebApp you can

- Monitor concrete conditions in real-time
- Access data from our sensors
- Detect potential issues early
- Navigate data easily
- Set up alerts and alarms
- Access detailed reports

4.1.1. Setting up a new project

After first powering on the ISC Hub you will be prompted to scan a QR code and start the process. You will be prompted to either choose an existing project or create a new one, but for the purpose of this chapter we will guide you through the steps of setting up a new project. To do this we need to open a web browser and go to <https://insite.peri.app/>



If at any point you need more guidance on the WebApp, press the 'help' button, located in the top right corner of the screen.

"Help" is located in the side menu on the top left corner. Replace with: ... guidance on the WebApp, start the onboarding tour on the information button on the top right corner.

For now, follow the steps below to create a new project

1. In the top left area, press the create new project button
2. In the next window, fill in your information about name, Location and your preferred units of measurements

After you have finished with the setup, you are ready to access your project, create dashboards and connect devices.

4.1.2. Creating a dashboard

After you have created your project we can now access it and go through the steps to further customize it to suit your needs. First, you should create a dashboard, a visual tool to gather your measurements in sections.

To setup a dashboard in your project, follow the steps below.

1. Press the "Create New Dashboard" button
2. Select a name for your dashboard
3. Add an image for your dashboard, or leave it blank and a stock image will be selected.

4.1.3. Connect devices to your project

With the project and dashboard set up, the next step will be to connect devices to your project. Click on "Devices". Under "Connect new unit" select the type of device you want to connect and follow the process.

4.1.4. Adding measurements

With the project and dashboard created and your devices connected to the project, we can set up measurements.

After entering your dashboard, you will see that a section is automatically created for you, by pressing the three dots on the right of that section, you can rename to something that suits your needs.

To begin your first measurement, follow the steps below.

1. Press the add measurement with button.
2. Select the type of measurement you want to set up, this will depend of the type of sensor you're using.
3. Select the devices you want to use for your measurement from the list.
4. Select the channels you want to use from the device
5. Assign a name for your measurement and select a start and end date for your measurement, or leave it with the default settings.
6. In the last step, you can choose to set up notifications for your measurements, such as min/max temperatures to get alerted when the sensor reaches the limits you set.

5 ISC Hub and Node

5.1. ISC Hub Technical details

Electrical characteristics		
	Input	12 V DC max, 2.5 A
Lithium-ion rechargeable battery	Total rated capacity	86.4 Wh / up to 12 W
	Rated voltage per cell	3.6 V
Charger/power supply unit	Input	100 ... 240 V AC, 50/60 Hz, 1.2 A max
	Output	12 V DC, max. 4.2 A, 50.4 W

Display		
	Screen	IPS LCD touchscreen monitor
	Size	7 Inches
	Resolution	600 × 1024 pixels
	Light sensor	Detection of ambient light to control the screen brightness
	LED display	4 × status LEDs

Operating temperature (discharging)	-5 ... 40°C (23 ... 104°F)
Ambient temperature when charging the battery	5 ... 40 °C (41 ... 104 °F) recommended 15 ... 25°C (59... 77°F)
Transport temperature	15 ... 25 °C (59 ... 77 °F)
Storage temperature	15 ... 25 °C (59 ... 77 °F)
Ambient humidity	L 90 % rH non-condensing

Emissions		
Noise Level	Unit signals	L 80 dBm at distance of 1 m

Interfaces, communication		
PERI bus	Serial interface	1 × 5-pin socket, digital, semi-proprietary
	Protocol	I ² C
	Function	12 V charging bus for battery
Ethernet	Serial interface	1 × 8-pin socket, digital
	Network	100BASE-TX
	Transmission rate	100 Mbit/s
WLAN	Protocol	TCP/IP
	Standard	IEEE 802.11 b/g/n
	Frequency band	2.4 GHz
LTE grid	EU frequency bands	Cat M1; 1, 3, 8, 20, 28 Cat NB2; 1, 3, 8, 20, 28
	US frequency bands	Cat M1; 2, 4, 5, 8, 12, 13, 25, 26, 66, 71 Cat NB2; 2, 4, 5, 8, 12, 13, 66, 71
Global Navigation Satellite System (GNSS)	NAVSTAR GPS	Positioning of the ISC Hub
	Frequency band	1550 ... 1600 MHz

Unit structure		
	Housing material	Plastic
	Protection type	IP66 pursuant to EN 60529

5 ISC Hub and Node

Unit structure		
	Weight	0,4 kg
	Over voltage category	OVC I
	Degree of pollution	3
	Usage	indoor and outdoor up to 2000 m a.s.l.
	Can also be used in wet locations. Definition of wet locations: The environment in which water or another conductive liquid may be present and in which it is likely that the resistance of the human body will be reduced by wetting of the contact between the human body and the device and by wetting of the contact between the human body and its environment.	

5.2. ISC Node Technical details

Electrical Characteristics		
	Input	12 V DC max, 0.5 A
Lithium-ion rechargeable battery (NITECORE NL2150)	Rated capacity	up to 17.28 Wh
	Rated voltage	3.6 V
	Number of cells	1

Display		
	LED display	4 × status LEDs

Ambient conditions Ambient conditions		
	Operating temperature (discharging)	-5 ... 40°C (23 ... 104°F)
	Ambient temperature when charging the battery	5 ... 40 °C (41 ... 104 °F) recommended 15 ... 25°C (59... 77°F)
	Transport temperature	15 ... 25 °C (59 ... 77 °F)
	Storage temperature	Indoor and outdoor 15 ... 25 °C (59 ... 77 °F)
	Ambient humidity	L 90 % rH non-condensing

Interfaces, communication		
PERI bus (Pressure sensors connection/ interface)	Serial interface	1 × 5-pin socket, digital, semiproprietary
	Protocol	I ² C
	Function	12 V charging bus for battery
Multifunction channel	Serial interface	4 × screw sockets, analogue, I/O
		Temperature measurement -15 ... +55°C (5 ... 131°F)
		Concrete detection and compaction measurement
WLAN	Standard	IEEE 802.11

Unit structure		
	Housing material	Plastic
	Protection type	IP66 pursuant to EN 60529

5 ISC Hub and Node

Unit structure	
Weight	0,4 kg
Over voltage category	OVC I
Degree of pollution	3
Usage	indoor and outdoor up to 2000 m a.s.l.
Can also be used in wet locations Definition of wet locations: The environment in which water or another conductive liquid may be present and in which it is likely that the resistance of the human body will be reduced by wetting of the contact between the human body and the device and by wetting of the contact between the human body and its environment.	

5.3. Dimensions

Figure 1:
Dimensions of Hub and Node
Measurements are displayed
in millimeters

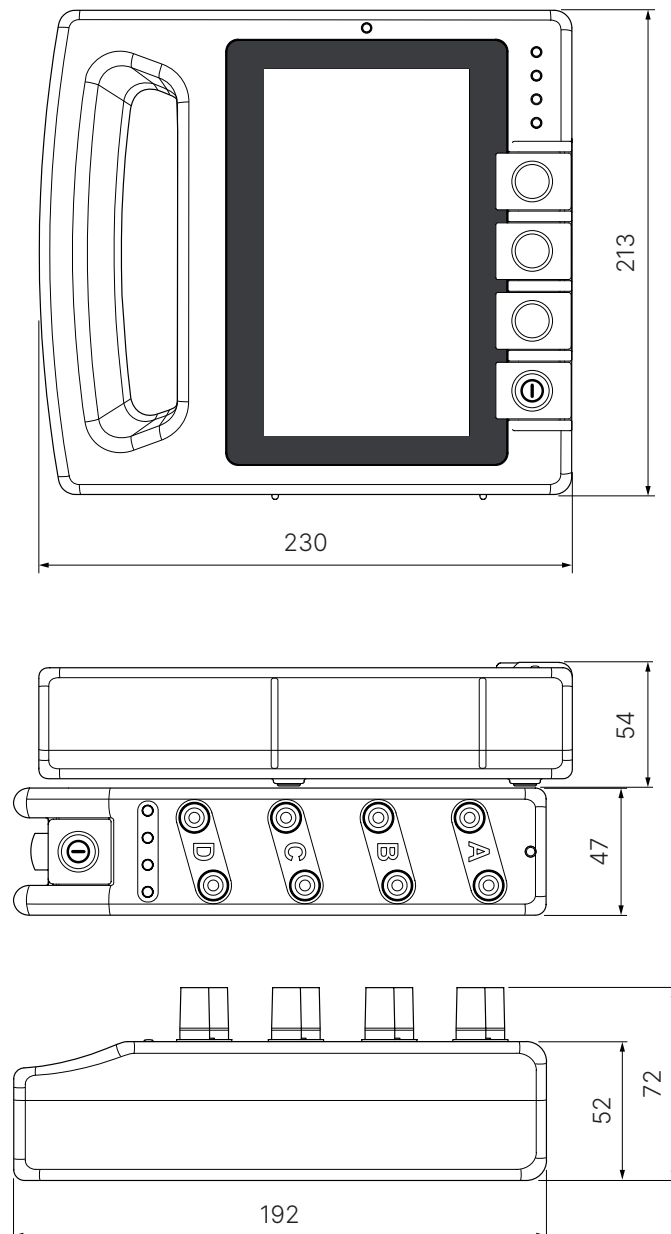

5 ISC Hub and Node

5.4. Hub and Node Overview

The Hub and Node are the core components of the system, responsible for collecting, monitoring, and uploading sensor data to the cloud.

Hub Main Screen

After powering on and setting up the system, the Hub Main Screen provides access to all system functions.

1. Status Bar:

Displays battery level, cloud connection status, Wi-Fi/LTE status, time, and other indicators.

2. Settings Button:

Opens the settings menu.

3. Power Button:

Powers off the unit.

4. Temperature:

Opens the temperature monitoring screen.

5. Pressure:

Opens the pressure monitoring screen.

6. Concrete Detection:

Opens the concrete detection and compaction screen.

7. All Sensors:

Opens a screen displaying all connected sensors with details about pressure, temperature, and detection.

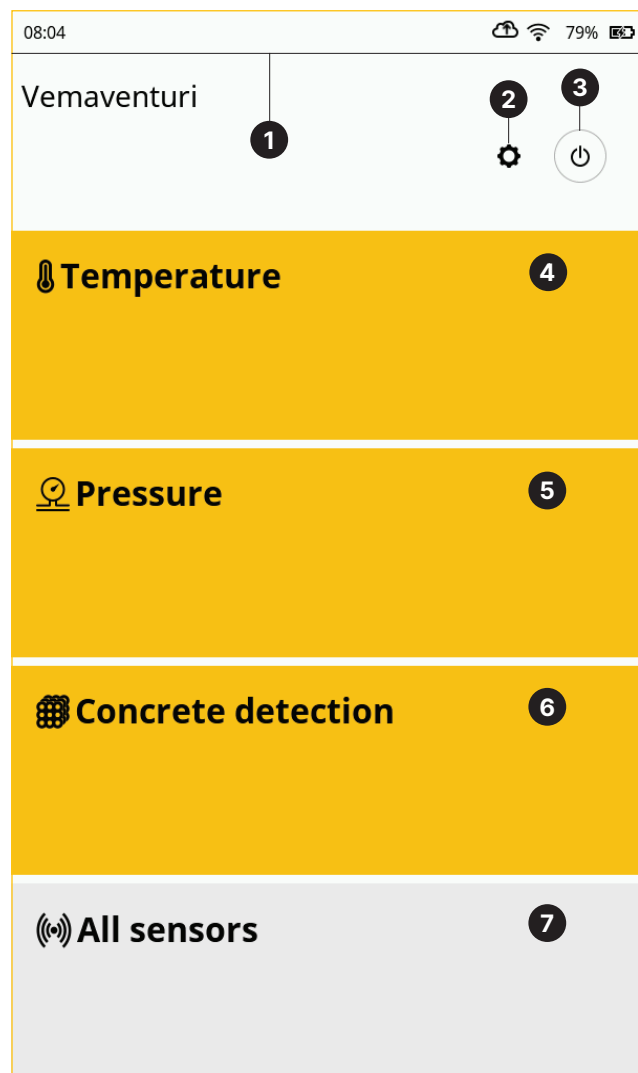

5 ISC Hub and Node

Settings Menu

Access the Settings Menu by selecting the cogwheel icon on the main screen. This menu allows you to configure and manage various aspects of the unit.

- 1. Home:**
Returns to the main screen.
- 2. System Information:**
Opens a screen displaying firmware details and notifications about available updates.
- 3. Memory Status:**
Opens a screen showing the status of the unit's internal memory.
- 4. Log Output:**
Opens a screen with diagnostic information useful for troubleshooting.
- 5. BMS Status:**
Opens a screen displaying battery information, such as load status and the temperature of individual battery banks.
- 6. Regional Settings:**
Opens a screen for changing the language, units of measurement, and manually setting the time and timezone.
- 7. New Project:**
Opens a screen to assign the unit to a new or existing project.
- 8. Connection:**
Opens a screen to switch between LTE and Wi-Fi or to select a Wi-Fi network.
- 9. Factory Reset:**
Restores the unit to factory settings.
- 10. Pairing:**
Opens the pairing menu, allowing you to: Pair nodes with the hub. Change node network modes
Erase data from nodes.
- 11. Node System Information:**
Opens a screen displaying details of nodes paired with the hub.
- 12. Pressure Sensor ID:**
Opens a screen to modify the channel for a connected PREMO pressure sensor.
- 13. Compaction Limits:**
Opens a screen that allows you to set limits for G-force and time.
- 14. Display and brightness:**
Opens a screen to change display settings.

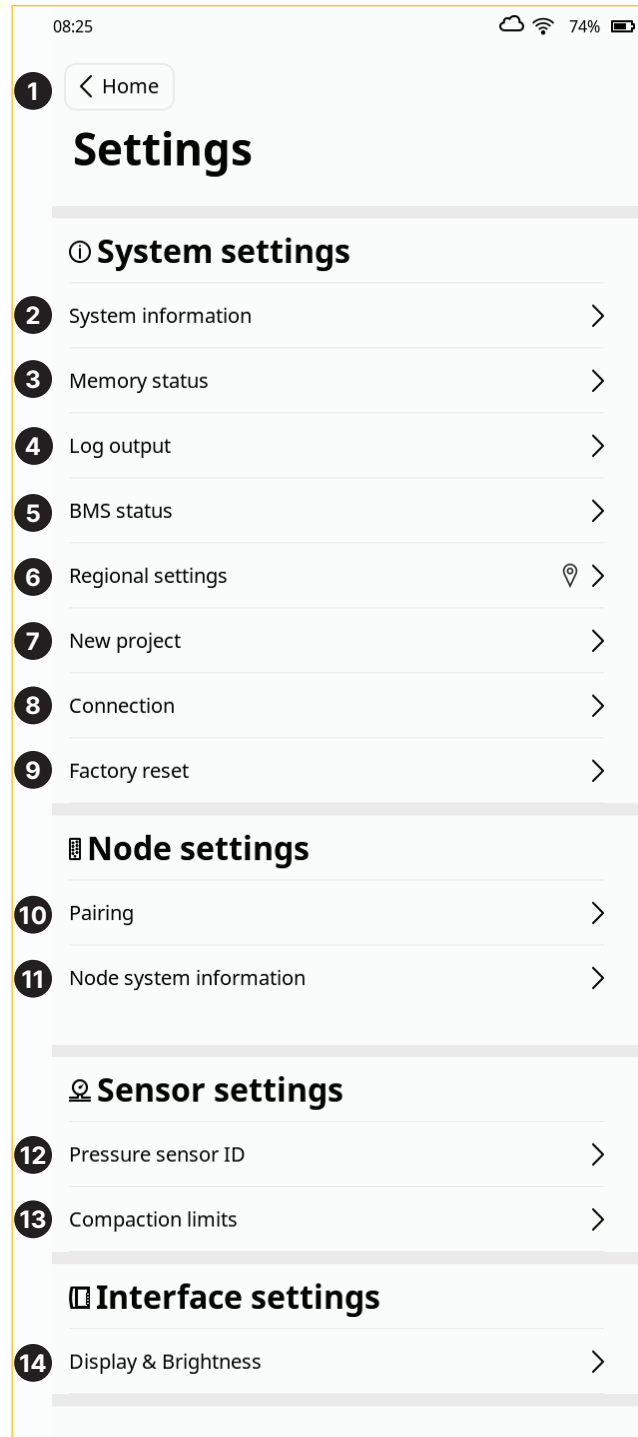

5 ISC Hub and Node

System Information Menu

The System Information Menu provides detailed information about the unit's status and allows you to manage firmware updates.

1. Settings:

Returns to the settings menu.

2. Current Version:

Displays the firmware version currently installed on the unit.

3. WSID:

Shows the WSID (Wireless System ID) associated with this unit.

4. LTE Info:

Displays information about the unit's LTE connectivity status.

5. FW Update Status:

Indicates if a new firmware version is available. If an update is in progress, it shows the download and installation progress.

6. Start:

If a firmware update is available, press the Start button to begin the download and installation process.



5 ISC Hub and Node

Regional settings

The Regional Settings menu allows you to customize the display language, measurement units, and time settings.

1. Settings:

Returns to the settings menu.

2. Language:

Change the display language of the unit.

3. Measurement System:

Switch between metric and imperial units for displayed measurements.

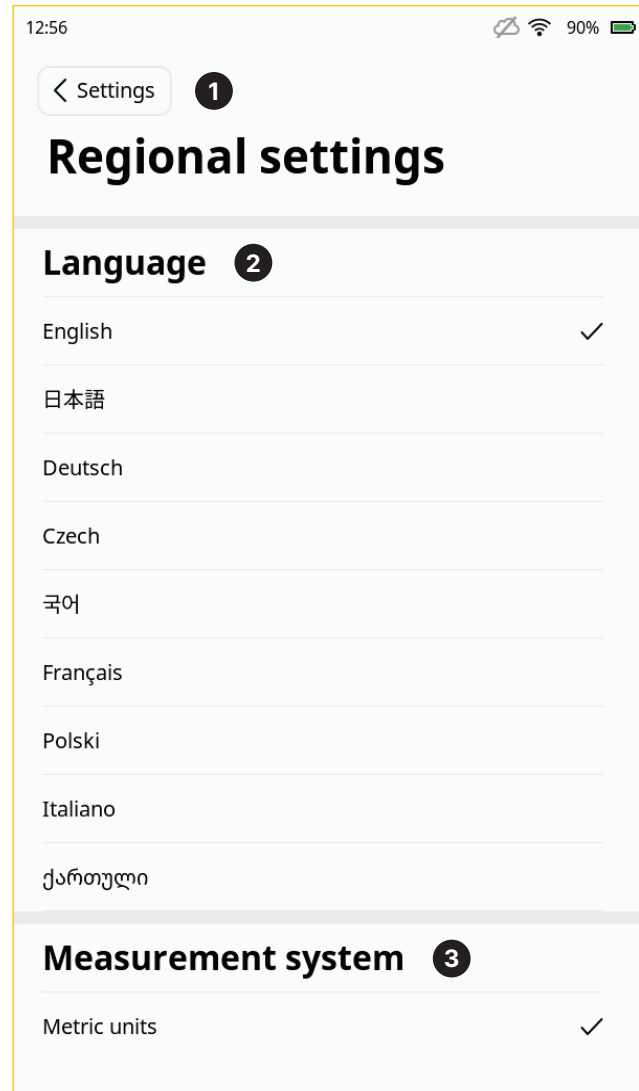

5 ISC Hub and Node

Pairing Menu

The Pairing Menu allows you to pair nodes with the Hub and configure their connectivity modes. For more details on Hub and Node connectivity options, refer to page 22.

1. Settings:

Returns to the settings menu.

2. Help Button:

Opens instructions for pairing a node with the Hub.

3. Paired Nodes:

Displays the WSIDs of currently paired nodes and provides an option to unpair them from the Hub.

4. Node Settings:

Adjust the logging interval for temperature readings. Switch the nodes network mode between Wi-Fi and mesh. Force-erase the memory of connected nodes.

5. PHONO Settings:

Enable or disable tunnel mode for the PHONO sensor.

Tunnel Mode allows the PHONO sensor to classify more liquid concrete as concrete, making it especially advantageous during concrete pours for structures such as tunnel valves.

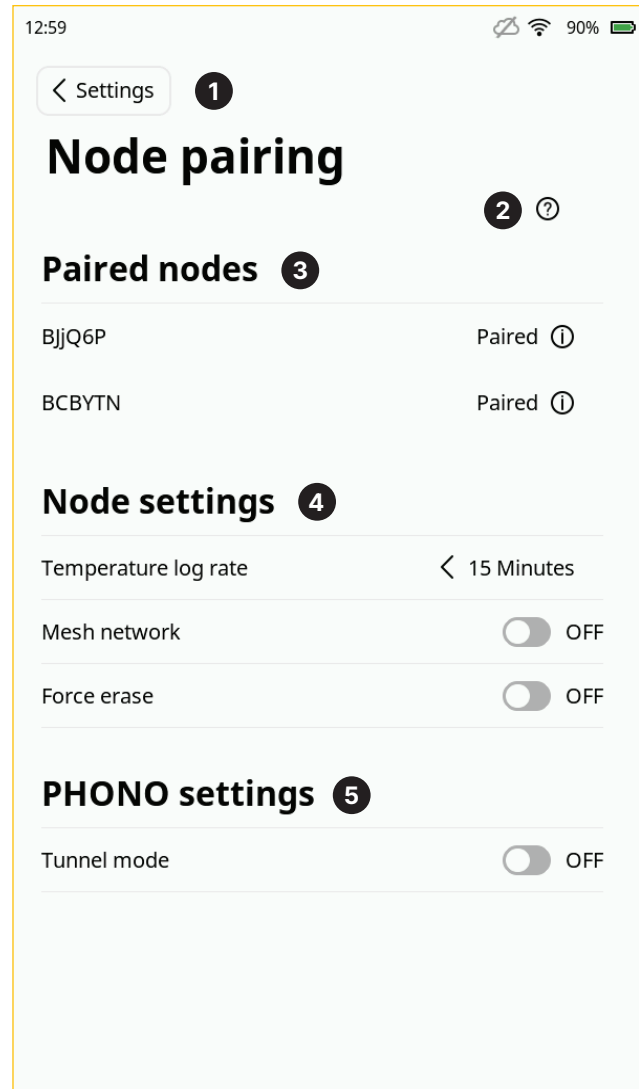

5 ISC Hub and Node

Node System Information

Selecting a paired node in this menu displays detailed information about that node.

1. Settings:

Returns to the settings menu.

2. WSID:

The WSID of the selected node.

3. Version:

The firmware version of the node.

4. Status:

Indicates whether the node is active or inactive.

5. Network Mode:

Displays whether the node is using Wi-Fi or Mesh mode.

6. Mesh State:

If the node is part of a mesh network, shows its current state within the mesh.

7. Last Status Packet:

Displays the time since the most recent data packet was received by the Hub, formatted as 0d0h0m00s (days, hours, minutes, seconds).

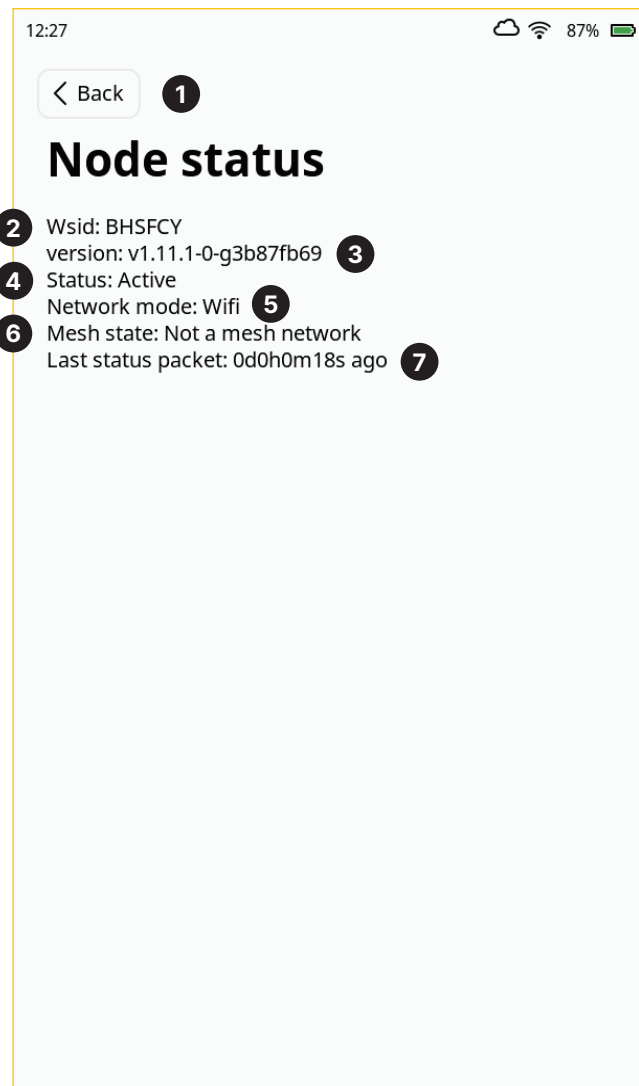

5 ISC Hub and Node

Pressure Sensor ID

The Pressure Sensor ID menu displays the ID and current slot of a PREMO pressure sensor when it is connected directly to the Hub. It also allows you to change the slot (A, B, C, D) to which the sensor is assigned.

1. Settings:

Returns to the settings menu.

2. Sensor Slot, Status, and ID:

Displays information about the PREMO pressure sensor currently connected to the Hub.

3. Slot Buttons:

Pressing one of these buttons allows you to change the slot (A, B, C, D) to which the PREMO pressure sensor is assigned.

For more information please see the chapter PREMO Concrete Pressure (Page 31).

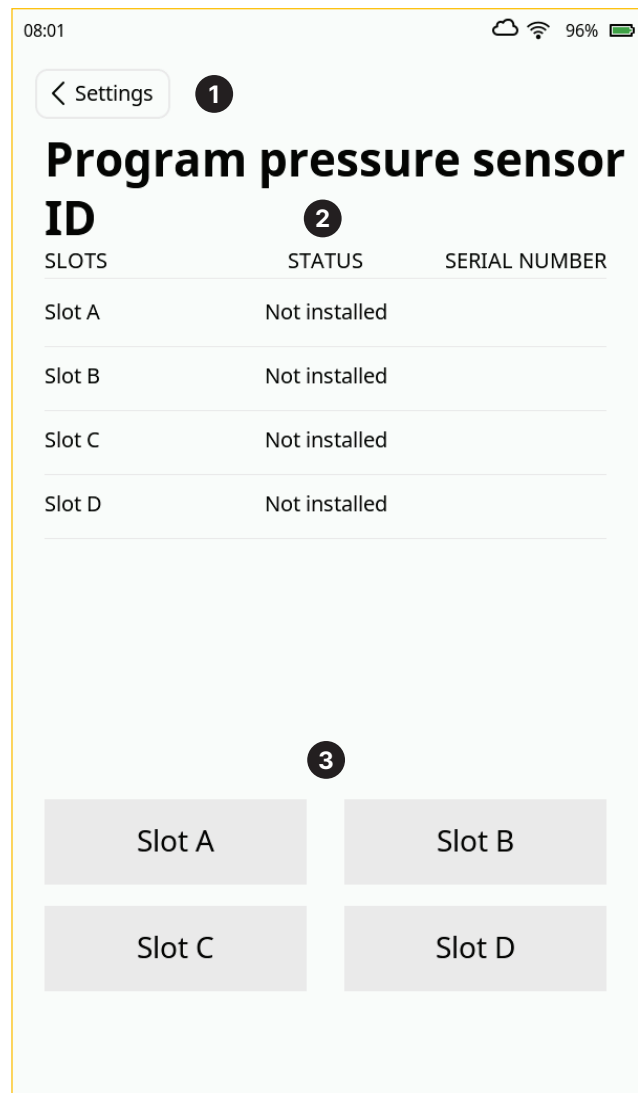

5 ISC Hub and Node

Compaction Limits

The Compaction Limits menu allows you to set limits for Gforce and time. These limits are then used for monitoring in the Concrete Detection screen, where three dots can be seen. When the G-force exceeds the set limit for the specified time, the dots will turn blue.

1. Settings:

Returns to the settings menu.

2. G-force Limit:

Set the G-force limit between 1G and 10G.

3. Time Limit:

Set the time limit between 5 seconds and 20 seconds.

For more information please see the chapter PHONO Concrete Detection (Page 39).

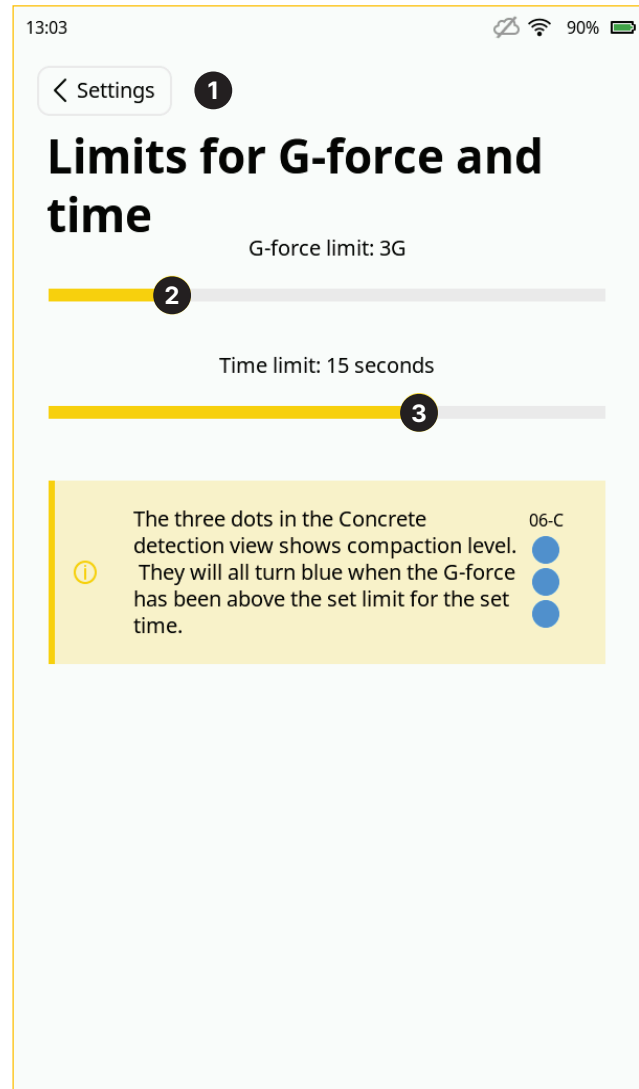

5 ISC Hub and Node

Display and Brightness

The Display and Brightness menu allows you to adjust the display brightness, toggle auto-brightness, and set the screensaver timer.

1. Settings:

Returns to the settings menu.

2. Brightness:

Drag the slider to set the display brightness to your desired level. Lower brightness helps conserve battery life.

3. Auto Brightness:

Toggle auto-brightness on or off. When enabled, the display automatically adjusts the brightness based on the surrounding ambient light.

4. Screensaver:

Select the desired screensaver timeout, with options ranging from Off, 30 seconds, 1 minute, and 5 minutes.

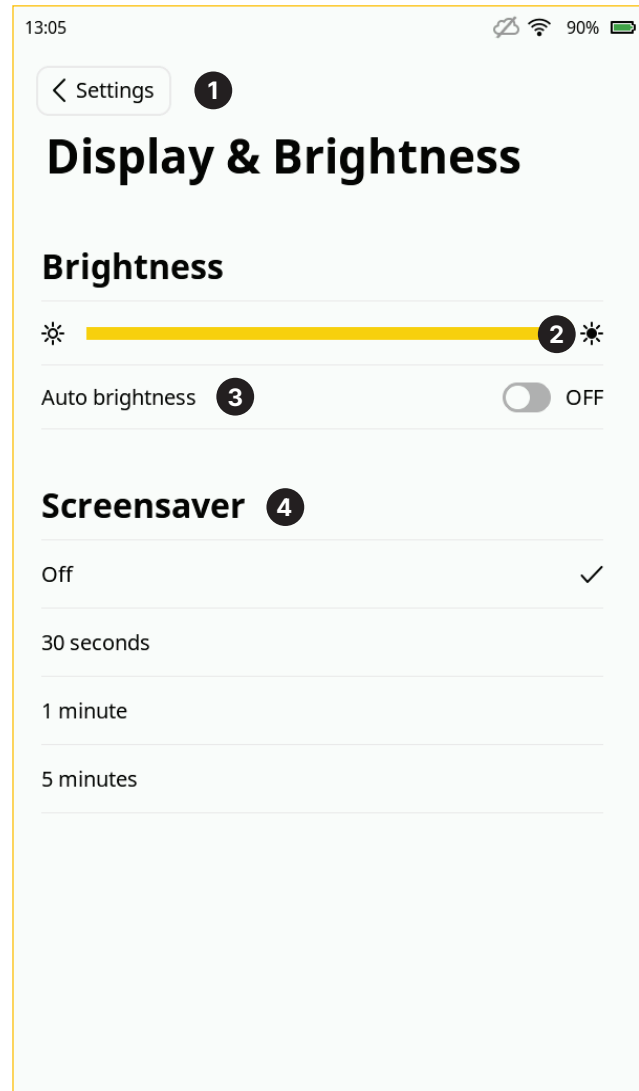

5 ISC Hub and Node

5.5. Network Connectivity Overview

The nodes communicate with the Hub via Wi-Fi (2.4 GHz), while the Hub can connect to the cloud service either via Wi-Fi or LTE using Cat M1 (bands 1, 3, 8, 20, 28) and Cat NB2 (bands 1, 3, 8, 20, 28). While these technologies provide extensive coverage, they can be subject to interference from various sources. The communication range between nodes has been tested at approximately 75 meters with a clear line of sight, but this range can be reduced due to physical obstructions or other unpredictable factors on construction sites.

Adverse weather (heavy rain or fog) can also have a negative impact on range.

A construction site is a dynamic environment and as the environment changes you may need to modify the layout of your Network.

There are two modes of communication between the Hub and Nodes:

- **Mesh Mode:**

In mesh mode, Nodes relay data through each other in a chain. Each Node only needs to maintain a connection with the next Node in line, allowing for extended range. For instance, with one Hub and four Nodes, the total distance between the Hub and the last Node can be up to 300 meters (Node > 75m > Node > 75m > Node > 75m > Node > 75m > Hub), as long as there are no significant obstructions between the nodes.

- **Wi-Fi mode:**

In Wi-Fi mode, all Nodes communicate directly with the Hub. This mode is optimal when Nodes are within range of the Hub and have a clear line of sight, allowing for faster and more direct data transmission.

To maximize communication range, ensure Nodes maintain a clear, unobstructed line of sight. In mesh mode, obstructions between Nodes can affect the relay of data, while in Wi-Fi mode, the signal between each Node and the Hub must remain strong for reliable communication.

5.6. Changing the network mode

To change between mesh mode and WiFi mode, follow the steps below:

1. Go to settings
2. Go to the pairing menu
3. Click on the mesh-mode switch
4. The system will inform you that this will unpair the Nodes that are currently paired with the Hub
5. Re-pair the Nodes

5 ISC Hub and Node

5.7. Mesh mode

1. Data Transmission from Nodes:

Nodes furthest from the hub (Nodes 1 and 2) send data to the next node in the chain (Node 3), which is closer to the hub.

2. Data Relay:

Node 3 then relays the data from Nodes 1 and 2 to the hub (4).

3. Data Upload to the Cloud:

The hub processes the data and uploads it to the cloud service (5).

4. Data Monitoring and Access:

Users can monitor the measuring data directly from the hub, or access and read it from the workstation (6).

Mesh mode: signal obstruction example

In mesh mode, if an obstruction blocks the signal between Node 2 and Node 3, data can still be transmitted to the hub from Node 1 and Node 3. However, if the signal path between Node 3 and the hub is blocked, no data will reach the hub from any of the nodes, as Node 3 is responsible for relaying data to the hub.

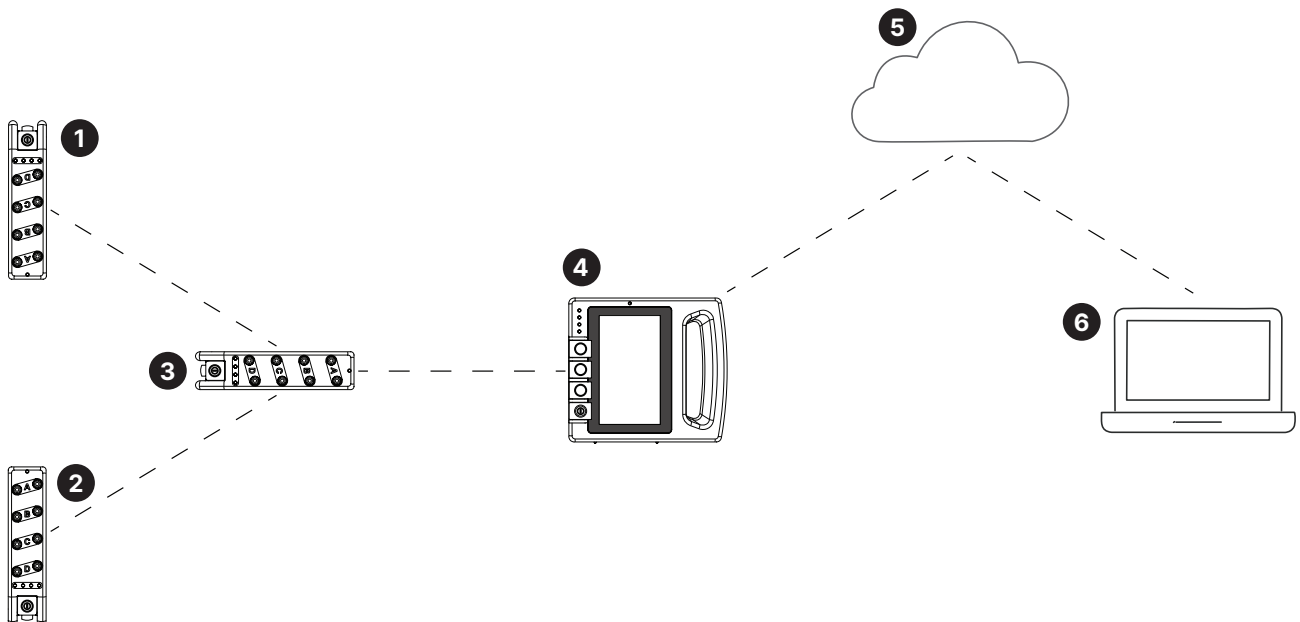

This diagram illustrates the network's operational process in mesh mode.

5 ISC Hub and Node

5.8. Wi-Fi mode

1. Direct Data Transmission:

In Wi-Fi mode, all nodes (1, 2, and 3) communicate directly with the hub (4), without relaying data through other nodes.

2. Data Upload to the Cloud:

The hub processes the data received from each node and uploads it to the cloud service (5).

3. Data Monitoring and Access:

Users can monitor the measuring data directly from the hub, or access and read it from the workstation (6).

Wi-Fi Mode: Signal Obstruction Example

In Wi-Fi mode, each node communicates directly with the hub. If an obstruction blocks the signal between Node 2 and the hub, only data from Node 2 will be affected, while data from Node 1 and Node 3 will continue to be transmitted without issue. In this mode, each node functions independently, so a blocked path affects only the specific node with the obstruction.

5.8.1. When to Use Wi-Fi Mode:

• Clear Line of Sight:

Wi-Fi mode is ideal when all Nodes have a direct, unobstructed line of sight to the Hub. This ensures faster, direct data transmission without needing intermediate Nodes to relay the signal.

• Close Range Setup:

If the Nodes are positioned close to the Hub, within the 100-meter range, and there are few or no obstacles between them, Wi-Fi mode is efficient.

• Simple Layouts:

For sites with a compact layout, where all Nodes can communicate directly with the Hub, Wi-Fi mode reduces complexity and provides quicker response times.

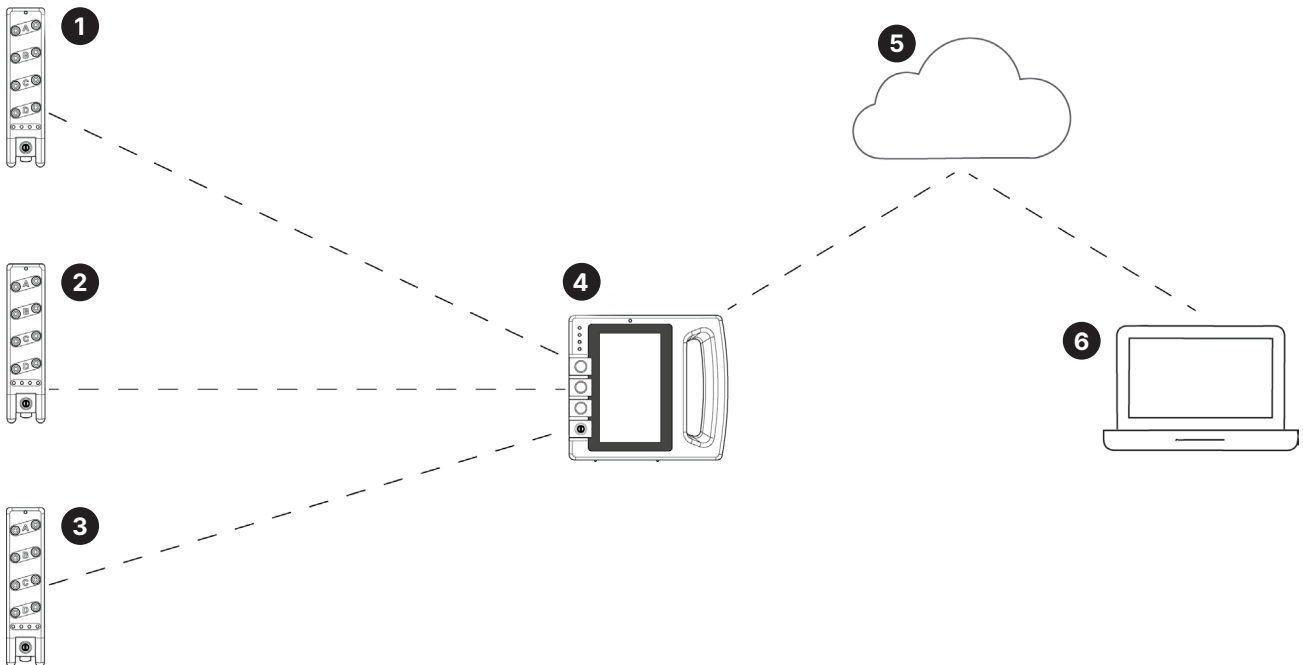

This diagram illustrates the network's operational process in Wi-Fi mode.

5 ISC Hub and Node

5.8.2. When to Use Mesh Mode:

- **Extended Range:**
Mesh mode is the best option when Nodes need to be spread out over a large area, beyond the 75-meter Wi-Fi range. In this mode, Nodes relay data through each other, significantly extending the overall communication range.
- **Obstructed Line of Sight:**
If there are obstacles like walls, machinery, or large equipment blocking the line of sight between Nodes and the Hub, mesh mode allows the signal to be relayed around these obstacles, ensuring stable communication.
- **Large or Complex Sites:**
On larger construction sites with complex layouts, where Nodes cannot all be in direct contact with the Hub, mesh mode enables you to maintain communication over longer distances and around obstacles.
- **Flexible Network Design:**
If the layout of the site is dynamic and constantly changing, mesh mode offers greater flexibility as Nodes can be repositioned, and the network can adapt by relaying signals through the nearest node.

5.9. Guide: Setting Up Nodes for Maximum Range

1. Plan Node Placement (for Both Modes)

Walk the site and identify potential obstacles (walls, steel, large equipment). Sketch a plan for where to place the Hub and Nodes, ensuring a clear line of sight for Wi-Fi mode or between individual Nodes for meshmode.

2. Position the Hub (for Both Modes)

Place the Hub in a central, elevated spot away from obstructions. Power it on and ensure it's ready for Node connections.

5.9.1. For Mesh Mode:

1. Place the First Node

Set the first Node within 75 meters of the Hub with a clear line of sight. Power it on and check that it connects to the Hub.

2. Add Additional Nodes

Place each additional Node within 75 meters of the previous Node, maintaining a direct line of sight between Nodes. Power on each Node and verify the connection to the chain.

3. Avoid Obstructions

Avoid placing Nodes behind walls, steel structures, or large machinery. If needed, elevate the Nodes to maintain visibility between them.

5.9.2. For Wi-Fi Mode:

1. Position All Nodes

Place each Node within 75 meters of the Hub, ensuring each Node has a direct line of sight to the Hub. Power on each Node and verify the direct connection to the Hub.

2. Avoid Obstructions

Ensure there are no major obstacles (such as thick walls, steel structures, or large machinery) between the Hub and each Node. Elevate Nodes or the Hub if needed to improve visibility and maintain direct connections.

5.10. Disclaimers

For optimal performance in mesh mode, it's recommended to have all connected Nodes measuring the same kind of data (pressure, compaction or temperature). This approach synchronizes the Nodes' wake-up times, significantly extending battery life per charge.

While it is possible to connect different types of sensors to each Node, be aware that battery life may decrease, as Nodes will need to stay active longer to relay the data. If you choose to connect different sensors, regularly monitor each Node's battery level to ensure it remains within an acceptable range.

The provider used for LTE connectivity offers coverage in a wide range of countries. However, local variations in network coverage may occur depending on the region, terrain, and specific site conditions. We recommend checking the availability and strength of the LTE signal onsite to ensure optimal performance. In cases of poor LTE coverage, Wi-Fi communication may be a more reliable alternative.

6 System Operation

6.1. Commissioning the System

6.1.1. Charging and Battery Status

Before use, ensure the ISC Hub and ISC Nodes are sufficiently charged. Battery status can be checked via the screen display or by observing the LED indicators on the unit.

For the ISC Node, check that all four LEDs illuminate when briefly pressing the function button. If fewer LEDs light up, charge the node before use.

6.1.2. Powering On and Off

Proper startup and shutdown procedures ensure reliable operation.

Switching on the ISC Hub

1. Ensure the Hub is sufficiently charged.
2. Press and hold the ON/OFF button until all four LEDs light up.
3. If only the screen is off, press any button or tap the display to wake it.

Switching off the ISC Hub

1. Press the power button icon on the touchscreen.
2. Confirm shutdown by selecting Power Off.

Switching on the ISC Node

1. Ensure the node is sufficiently charged (all four LEDs should illuminate when briefly pressing the function button).
2. Press and hold the function button until all four LEDs light up green.

Switching off the ISC Node

Press and hold the function button until the LEDs turn off sequentially.

6.1.3. Pairing the ISC Node with the Hub

Pairing between the ISC Node and ISC Hub occurs immediately after the node is switched on.

Pairing Procedure:

1. Switch on the ISC Hub and ISC Node.
2. The node automatically enters pairing mode, indicated by flashing blue LEDs.
3. Press the function button on the Node three times to initiate pairing.
4. The nodes LEDs will flash blue rapidly to indicate pairing.
5. Once paired, the node returns to normal operation, and the LEDs indicate its status.

Note: If there is a firmware update available for the Node, it will indicate with white flashing LEDs on the Node and the Hub will say that an update is in progress. Do not try to pair other Nodes to the Hub while this update is in progress.

Note: If the node does not pair within 30 seconds, it will automatically switch off.



A maximum of 8 Nodes can be paired to a single Hub.

Installation and Positioning

For optimal performance, the ISC Hub should be installed in a location free from physical obstructions (e.g., walls) and potential sources of interference.

The ISC Node should be positioned securely using built-in magnets for metal surfaces or cable ties.



You can find more information in the video of the pairing process.

7 Maintenance and storage

Store and transport the unit in a way that prevents unintentional movements or potential damage.

Do not drop the unit.

Use original Vemaventuri storage and transport systems whenever possible.

Protect the unit from exposure to the water, weather, oils, and aggressive substances that could affect safety.

Cleaning

- Do not use aggressive chemical agents or abrasives when cleaning.
- Avoid using hard sponges.
- Repairs must only be performed by the manufacturer.
- Only original components may be used for repairs.

8 Recycling and disposal

8.1. Disposal



The units must be disposed of and recycled in accordance with local environmental protection regulations.

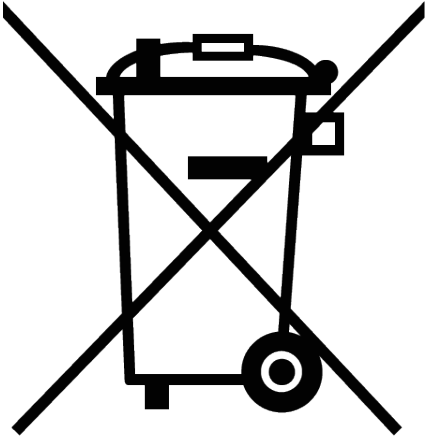











9 Troubleshooting

9.1. ISC Hub and Node

Fault	Possible cause	Remedy
If nothing happens when the unit is switched on and LED 1 does not flash	Battery flat	Charge the battery
	Charger/power supply unit defective	Check charger and replace if necessary
Screen remains dark after switching on, LED 1 flashes	The Hub is in "Dark" operating mode	Press any button or tap the screen. The Hub switches to the operating mode "Fully active" and the screen switches on
	System fault	Press and hold the power button for 20 seconds. The system is reset and rebooted
	Screen defective	Contact the manufacturer's service department Return the unit
No measured data is received from the node	The Node and Hub are not paired	Pair the Node and Hub, see section "Pairing the Node and Hub"
	Node is outside the radio range of the Hub	Reduce the distance between the Node and the Hub or change the network mode to "mesh-mode", see page 22
	The Node is switched off	Switch on the Node using the function button, see section "Switching on the Node"
	The sensor is not connected correctly	Check that the connections and cables are intact, see the chapter of the sensor concerned
	A sensor or connection cable is amaged	<ul style="list-style-type: none"> • Check the connections and cables for damage • Do not use damaged sensors and cables • Contact the manufacturer's service department • Return the sensor and cable
	The Node is switched off or out of radio range	See above
No measured data is being sent to the cloud	The Hub or Node are switched off	Check that both units are switched on and paired
	No mobile radio connection	<ul style="list-style-type: none"> • Check the signal quality at the Hub in the status bar. If there is no signal, change location • If a mobile radio connection cannot be established despite a change of location, connect the Hub to the cloud via LAN

































10 LED Indicators Hub and Node

10.1. LED indicators Hub

State	LED 1	LED 2	LED 3	LED 4	Description
Steady green					System is booting. The four LEDs light up green one after the other until all four LEDs are lit
Steady green					Connection between Hub and cloud is established
Flashing green					The Hub and Node are connected. The Hub is receiving measured data from the Node
Flashing green					Measured data is being uploaded to the cloud
Steady green					Battery is fully charged
Steady yellow					Battery is halfcharged
Steady red					Battery is almost flat

10 LED Indicators Hub and Node

10.2. LED indicators Node

State	LED 1	LED 2	LED 3	LED 4	Description
Steady green					Turning On/Off: Hold the Function button. LEDs will light up sequentially when turning on or turn off one by one when powering down
Steady green					Node is paired with the hub and ready to start measurements
Flashing yellow					Node is paired with the Hub but not yet synced (not ready for measurements). Exit the "pairing menu"
Flashing blue					After booting: LEDs flash blue to indicate the Node is ready for pairing
Flashing blue rapidly					Node is in pairing mode and trying to pair with the Hub
Steady blue					LEDs light up blue for 2 seconds. The Node has paired successfully with the Hub and is switching back to the operating mode
Steady green					All 4 LEDs light up green for about 1 minute 40 seconds. Internal memory is being erased
Flashing red SOS					LEDs flash "SOS" (3 times fast, 3 times slow, 3 times fast). The Node has detected a hardware error
Steady red					LEDs will light up red for 2 seconds. Firmware update interrupted or unable to update
Flashing white					Ongoing software update is processing

11 System Peripherals

The ISC system supports a range of sensors and measuring devices designed to provide precise data for monitoring various aspects of your construction project. These sensors connect to the ISC Node, enabling realtime data collection and analysis.

The following sensors are available for use:

- **PREMO Concrete Pressure Monitoring**
- **TEMO Concrete Temperature and Maturity Monitoring**
- **PHONO Concrete Detection and Compaction Monitoring**

Each sensor is built to address specific monitoring needs, ensuring the ISC system can adapt to a variety of construction scenarios. Detailed installation instructions and usage guidelines for these sensors can be found in their respective chapters.

12 PREMO Concrete Pressure Monitoring

12.1. Technical details

Properties		
Pressure transducer	Type	DPS 5000
	Power supply	2.7 ... 3.6 V DC, 2 mA
	Working pressure	0 ... 2 bar (0 ... 200 kPa)
	Precision	± 0.1 % FS (full scale)
	Output signal	I2C digital

Ambient conditions		
	Operating temperature	-15 ... +55°C (5 ... 131°F)
	Ambient humidity	L 95 % rF non-condensing

Interfaces, communication I2C digital		
PERI bus	Serial interface	1 × 5-pin socket, digital, semiproprietary
	Protocol	I ² C

Unit structure		
	Material, housing	Stainless steel
	Membrane filling	Glycerol
	Protection type	IP68
	Weight	0.86 kg

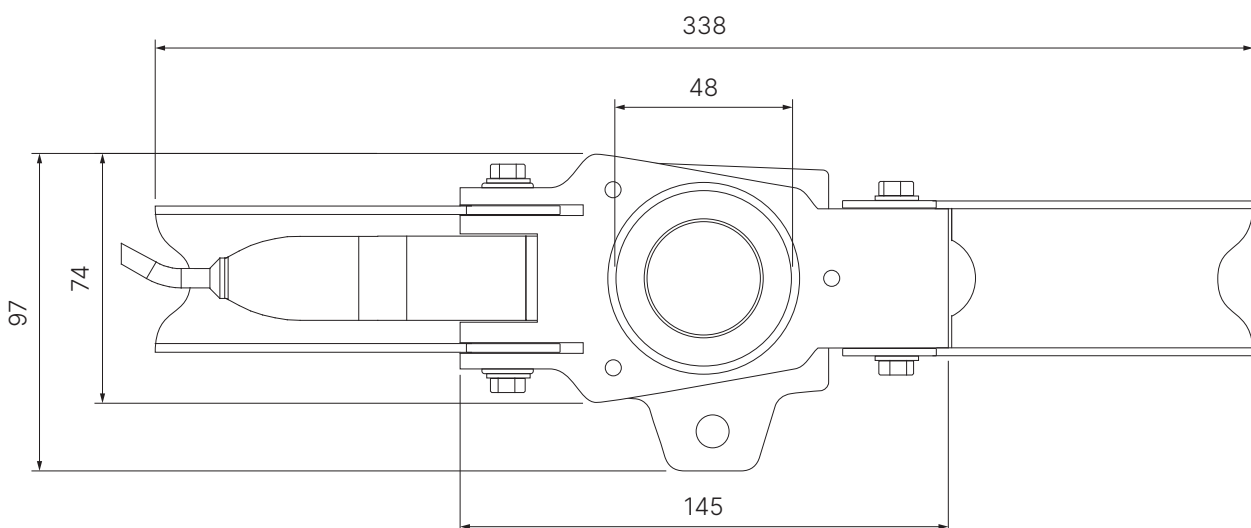

We provide PREMO pressure sensors in sizes of 21 mm and 42 mm to accommodate different plywood thicknesses, and spacers are available for intermediate dimensions.

Figure 1:
Dimensions of PREMO sensor
Measurements are displayed in millimeters

12 PREMO Concrete Pressure Monitoring

12.2. Fitting and connecting the pressure sensor

12.2.1. Preparation

- Determine and mark the positions of the sensors.
 - The distance between the sensors should be approx. 1.5 m for an 8-m-high wall.
 - Position the sensors in the lower part of the formwork.
 - An additional series of sensors will increase the accuracy.
- Check the sensor cable, connector, housing and membrane for damage and ensure that the filling is free of bubbles.
- Have a drill with a 50 mm hole saw and centre drill, (drilling template (only for PREMO DUO) screws and grease (e.g. Vaseline) to hand.

12.2.2. Installing the sensor group

12.2.2.1. PREMO Sensor

1. Drill the hole for the sensor into the formwork using the hole saw. – Make sure that there is enough space for the sensor housing.
2. Grease the membrane and housing (recommendation: Vaseline).
3. Place the sensor on the formwork and pre-drill the holes for the screws.
4. Tighten the sensor with 3 screws. (Figure 1)



Figure 1

5. Affix the Node safely and securely near the measuring points.
6. Connect the sensors to the PERI bus connection of the Node and to each other using XLR-cables and splitters as needed. (Figure 2)
7. **Switch on the Node.**
The measured data from the sensor is received automatically.
8. **Switch on the Hub.**
Measurements can also be taken when the Hub is switched off. The measured values are stored in the Node. The Hub receives the stored values as soon as it is switched on.
9. Document the node number and position or installation heights of the pressure sensor in the formwork.

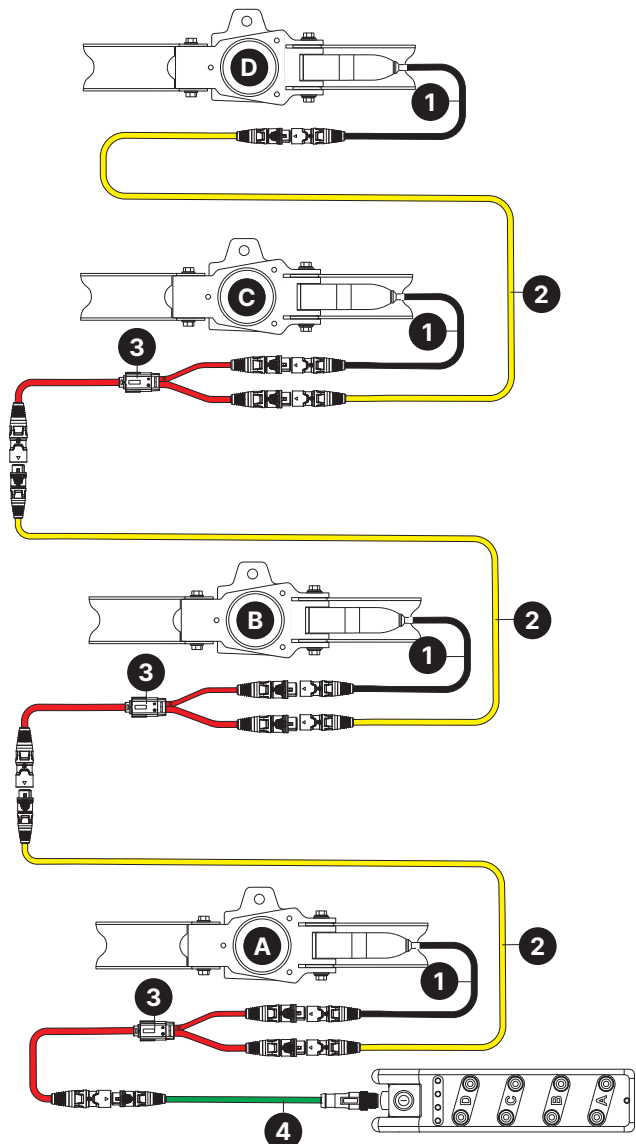

Figure 2

12 PREMO Concrete Pressure Monitoring

12.2.2.2. PRMEO DUO Sensor

1. Determine and mark the positions of the sensors.
 - The distance between the sensors should be approx. 1.5 m for an 8-m-high wall.
 - Position the sensors in the lower part of the formwork.
 - An additional series of sensors will increase the accuracy.
2. Fix the drilling template to the DUO formwork. (Figure 3)
Drill the hole for the sensor into the formwork using the hole saw.
3. Grease the membrane and housing (recommendation: Vaseline).
4. Place the sensor on the formwork and tighten the sensor with 2 screws at the top and bottom. (Figure 4)
5. Install the protective cover and secure it with two screws on the right and left sides (Figure 3).
6. Affix the Node safely and securely near the measuring points.
7. Connect the sensors to the PERI bus connection of the Node and to each other using XLR-cables and splitters as needed. (Figure 5)
8. **Switch on the Node.**
The measured data from the sensor is received automatically.
9. **Switch on the Hub.**
Measurements can also be taken when the Hub is switched off. The measured values are stored in the Node. The Hub receives the stored values as soon as it is switched on.
10. Document the node number and position or installation heights of the pressure sensor in the formwork.



Figure 3

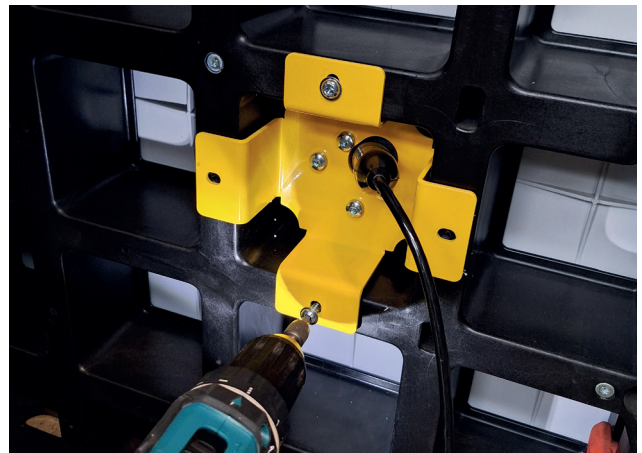

Figure 4



Figure 5

12 PREMO Concrete Pressure Monitoring

12.2.3. Checking the functional integrity

Check the functional integrity and data transmission before concreting.

By pressing the black button on the node a force connect and upload is initiated, indicated by all LEDs flashing orange and then blue.

The Hub's Pressure screen displays the status and readings of the connected sensors.

You can check there whether all the measured data is being received correctly.

The current pressure is displayed in kilopascals (kPa).
1 kPa = 0.01 bar.

12.2.4. Assigning IDs to the sensors

To pair the sensors and assign IDs, follow the steps below for each individual sensor.

1. Connect a PREMO sensor directly to the Hub.
2. Access the settings menu by tapping the cogwheel icon on the Hub's home screen.
3. Navigate to the sensor settings menu.
4. Select 'Pressure sensor ID'.
5. Assign a unique ID position (A, B, C, D) to the connected sensor.

It's essential to repeat these steps for each additional sensor to maintain accurate readings and avoid potential conflicts.

12.3. Deinstallation

1. Disconnect the bus cable connector from the Node and pressure sensor.
2. Disconnect the connecting cables between the sensors.
3. Unscrew the sensors from the formwork.
4. Clean the housing and membrane.
 - Do not use pointed or sharp objects.

12.4. Troubleshooting

Possible causes of unsuccessful measuring:

- No pressure sensor connected
- Defective connecting cable
- Pressure sensor damaged (pressure transducer or leaky membrane)
- Node not switched on or low battery

12 PREMO Concrete Pressure Monitoring

12.5. Maintenance

12.5.1. Replacing the membrane

1. Cleaning cloth
2. Syringe without needle (approx.20 ml)
3. Screwdriver (TORX T15)
4. TORX bit T10
5. Glycerol
6. Base plate
7. Membrane
8. Screw ring with O-ring

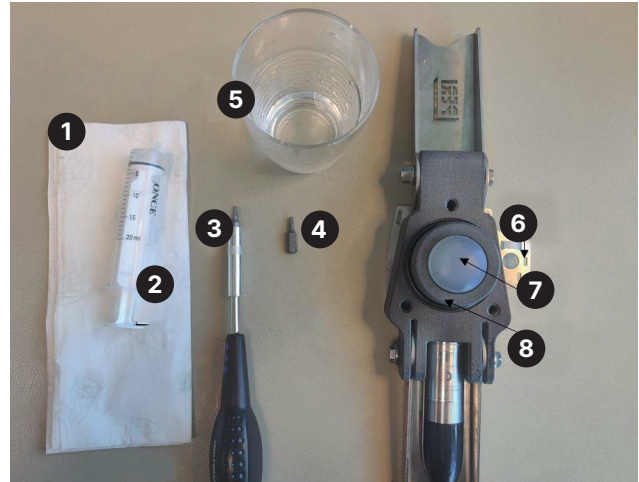

Instructions

1. Unscrew the base plate.
2. Carefully clean the inside and outside of the housing if it's dirty.
3. Unscrew the bleed screws.
4. If the membrane is not ruptured, pour the glycerol through the vent holes into a container.
5. Press on the undamaged membrane to squeeze out the remaining liquid through the vent holes. The glycerol can be reused if it is clear and free of dirt particles.
6. Unscrew the screw ring counterclockwise by hand. Using a damp cloth may improve your grip.

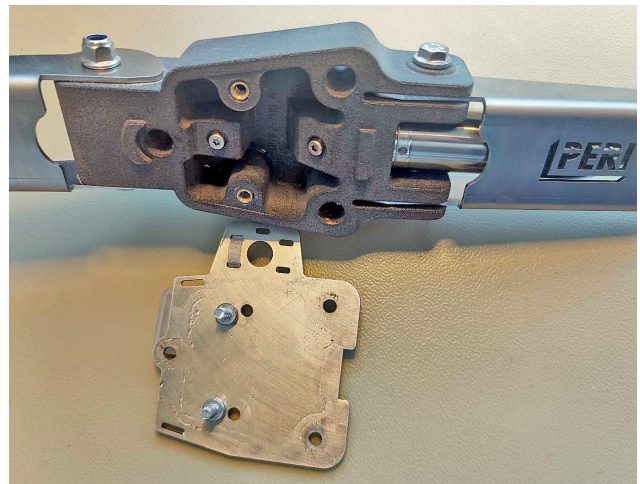

12 PREMO Concrete Pressure Monitoring

7. Remove the damaged or old membrane from the screw ring.
8. Clean the screw ring.
9. Insert the new membran



10. Replace the O-ring if it is worn or damaged.
11. Wipe the threads in the screw ring and on the sensor housing until dry. This will make it easier to spot any leaks later on.
12. Screw the screw ring onto the sensor housing and tighten it by hand.



13. Fill the syringe with glycerol. When drawing up the syringe, do not allow air bubbles to form.
14. Keep the sensor housing horizontal and insert the syringe into the vent hole (hole closest to the pressure transducer).
15. Pour glycerol into the housing until it emerges at the vent hole.

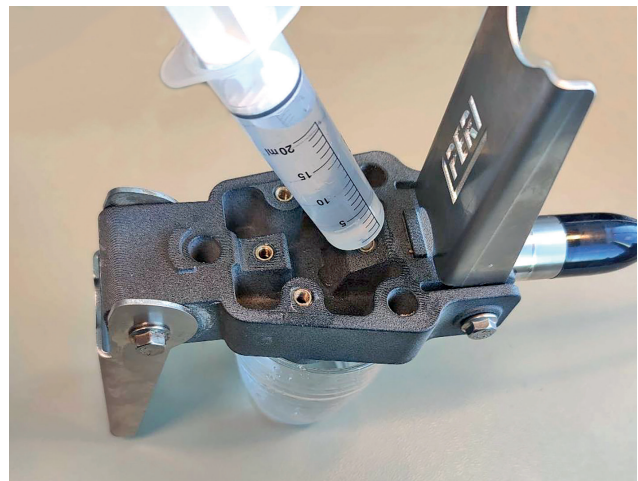

12 PREMO Concrete Pressure Monitoring

16. Remove the syringe and close the opening with a bleed screw. Leave the second vent hole open.
17. Tilt the sensor housing by approximately 45 degrees so that the open vent hole is at the top and the pressure transducer is at the bottom.
18. Carefully press on the membrane with your finger until liquid can be seen in the vent hole. Keep the pressure on the membrane.



19. Remove the syringe and close the opening with a bleed screw.
20. Turn the unit with the membrane facing upwards and hold it horizontally.
21. Repeat steps 17 to 21 if air bubbles are visible beneath the membrane.
22. Carefully wipe the housing and the bleed screw until they are dry.
23. Press on the membrane for several seconds with the heel of your hand, using only a little force. Check the housing for leaks.



You can find more information in the video of the membrane replacement.

13 TEMO Concrete Temperature and Maturity Monitoring

13.1. Technical details

Properties	
Type	T, surface Thermocouple
Temperature range	-40 ... +100 °C (-40 ... 212 °F)
Cable length while measuring	0-100 meters
Limit deviation	± 0.5 °C
Tolerance class	1 pursuant to IEC 60584-1
Environmental conditions	
Operating temperature	-15 ... 55 °C (5 ... 131 °F)
Storage temperature	15 ... 25 °C (59 ... 77 °F)
Ambient humidity	L 95 % rF non-condensing
Structure	
Material	Copper and copper-nickel
Cabling	Twin cable, PVC insulated
Weight	3.6 kg (coil)
Cable length	100 m (coil)

13.2. Calibration for Concrete Maturity Monitoring

This section describes the end-to-end procedure to calibrate a concrete mix for maturity-based, real-time strength estimation. Follow these steps before using in-place maturity results to make decisions such as striking formwork, removing cold-weather protection, or opening to traffic. Requirements and actions below align with common industry practice (e.g., ASTM C 1074, DIN EN 12390-2) for specimen preparation and curing.

1. Preparation:

Plan for a minimum duration of 28 days or until the design strength is reached. Use the same concrete mix intended for the structure and prepare between five and fifteen cubes or cylinders according to your local standards. Label each specimen with its casting date. Install a Vemaventuri temperature sensor, in the center of at least one specimen, ideally the last one scheduled for crushing. Cure all specimens according to local standards, such as a 20 °C water bath in compliance with DIN EN 12390-2.

2. Crushing Schedule and Data Capture:

Carry out compressive strength tests at 1, 2, 3, 7, and 28 days. If early decisions are anticipated, include additional intervals during the first few days. For each specimen, record the exact crushing time and the measured compressive strength in megapascals.



Increasing the number of specimens improves the accuracy of the calibration curve by reducing variance. If speed is critical, plan additional early-age tests to refine the strength trajectory for early decision-making.

3. Create the Concrete Calibration:

In the WebApp navigate to Menu → Concrete → Concrete Calibration and select "Create New Concrete Calibration." Enter the required details, including basic information, concrete data, and the temperature channels linked to the embedded sensor.

13 TEMO Concrete Temperature and Maturity Monitoring

4. Maturity-Strength Calibration Output:

Once all data is entered, the WebApp will generate a maturity–strength curve based on recognized methods such as Saul or Arrhenius, as referenced in e.g. ASTM C1074. This curve enables estimation of in-place strength using sensor temperature data collected on site. (Figure 1)

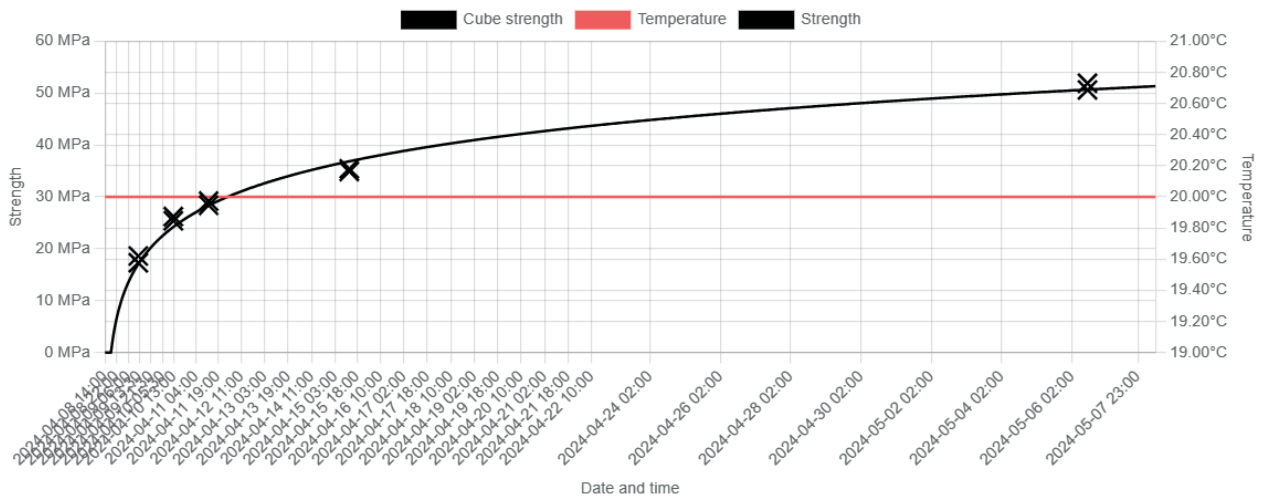

Figure 1: Calibration

13.2.1. Quality and Safety Considerations

Maintain a complete calibration log that includes specimen identifiers, casting dates, curing conditions, crushing timestamps, strength results, and linked sensor channels. This documentation supports audits and compliance. While the calibration process aligns with DIN EN 12390-2 and ASTM C1074, correct application and interpretation remain the responsibility of the user. Always review local codes and project specifications before relying on maturity results for structural decisions.

13 TEMO Concrete Temperature and Maturity Monitoring

13.3. Installation



Risk of incorrect measurements or damage to the thermocouple!

- Do not use binding wire, nails or staples to fasten the thermocouple.
- Only establish or release connections when the node is switched off.
- Only the thermocouple supplied and approved by the manufacturer may be used.
- Do not extend the thermocouple with other cables or wires.

13.3.1. Attaching and connecting up the thermocouple

Place the thermocouple in a position inside the formwork that will be completely filled with concrete.

13.3.2. Preparation

- Check the thermocouple cable for any visible damage.
- Have your choice of cable ties, adhesive base and adhesive tape to hand.

1. Find a suitable position in the formwork to use as the measuring point.
2. Strip the insulation from the thermocouple at the measuring point in the formwork by at least 15 mm and twist the wires together. The thermocouple only becomes functional when the wire ends make conductive contact. (Figure 1)
3. Protect the twisted measuring end with a shrink sleeve or insulating tape. (Figure 2)
4. Position the thermocouple safely in the formwork and fix it with cable ties or adhesive tape.
5. Fit the Node close to the measuring points outside the formwork in a safe and secure manner.
6. Cut the thermocouple cable to length up to the Node and route it over or through the formwork.
7. Split or strip the end of the cable with a knife and strip the insulation from the wires by at least 12 mm. (Figure 3)
8. Connect the wires to a measuring channel on the Node: (Figure 4)
 - Unscrew the pole terminal until the stripped wire end can be wrapped around the threaded bolt once.
 - Connect the brown wire to a brown terminal (+).
 - Connect the white wire to the white terminal (-) of the same channel.
 - Only ever connect one thermocouple to a channel.
9. Screw the pole terminals back on until they are handtight.

10. Switch on the Node. The measured data is received automatically from the connected sensors.
11. Switch on the Hub.
12. Document the Node number and channel of each thermocouple
 - When measuring the core temperature and nearsurface temperature in a concrete body, document the exact position of each sensor.
 - If the temperature in cooling or heating lines is measured, document which thermocouple is attached.



Figure 1: Measuring point



Figure 2: Measuring point with shrink sleeve



Figure 3: Cable end at the measuring channel



Figure 4: Node connection



It is also advisable to note the fixing locations of the Nodes. On an ever-changing construction site, it can be difficult to find the units again.



You can find more information in the video of the installation process.

13 TEMO Concrete Temperature and Maturity Monitoring

13.3.3. Checking the functional integrity

Check the functional integrity and data transmission before concreting. By pressing the black button on the node a force connect and upload is initiated, indicated by all LEDs flashing orange and then blue. The Hub's **temperature** screen displays the status and readings of the connected sensors. You can check there whether all the measured data is being received correctly.

Faults

Possible causes of unsuccessful testing:

- The thermocouple is not properly connected to the Node, e.g. incorrect polarity
- The wires of the thermocouple are not twisted correctly at the measuring point
- The thermocouple is damaged (line break)
- Node not switched on or low battery
- Data transmission or the WLAN between the Hub and the Node is disrupted.



The thermocouple can be tested using the diode test function of a multimeter.

The operation of the Hub and the Node as well as the web application is described in the **"ISC Hub and Node"** chapter in this manual.

13.4. Removal

1. Switch off the Node.
2. Loosen the pole terminals and pull out the wires.
3. Cut the thermocouple cable flush with the concrete. Cables or thermocouples that have not been cast into the concrete can be reused.



Check the cables for damage and functional integrity before they are used again.

13.5. Troubleshooting

Symptom	Solution
Data is not being received	Ensure that Hub and Node is paired and switched ON
Temperature readings are way too high/low	Check connections at measuring channel. Check that measuring point is properly insulated

14 PHONO Concrete Detection and Compaction Monitoring

14.1. Technical details

Properties	
Type	Piezoelectric sound element
Frequency range	2 to 14 kHz
Power supply	12 VDC
Water pressure	Max. 0.3 MPa
Environmental conditions	
Operating temperature	0 to +40 °C (32 to 104 °F)
Storage temperature	-10 to +60 °C (14 to 140 °F)
Structure	
Housing material	Plastic
Weight	Article no. 137075: 0.06 kg / Article no. 137086: 0.21 kg
Cable length	5 or 20 metres

14.2. Attaching and connecting up the sensor

Place the replace: PHONO detection and vibration sensor in a position inside the formwork that you cannot see or that is difficult to see during the concreting process, but needs to be completely filled with concrete. Or place it inside the formwork where you want to monitor compaction measures.

14.2.1. Preparation

- Check the sensor head and cable for damage.
 - Have your choice of cable ties, adhesive base, adhesive tape and adhesive (e.g. epoxy glue) to hand.
1. Find a suitable measuring point. The substrate must be clean, smooth and robust, i.e. formlining, rock or concrete.
 2. Remove the protective film from the adhesive surface of the sensor
 3. Press the edges of the sensor firmly onto the substrate.



Do not apply pressure to the sound element in the middle.



In cold temperatures, warm up the adhesive surface before fixing in order to increase the adhesive strength. If the adhesive strength of the double-sided adhesive surface is not sufficient, for example for rough and uneven substrate, then add more adhesive. The sound element must remain free of adhesive. Alternatively, the sensor can be fixed to the reinforcing steel with cableties and an adhesive base.

4. Lay the cable safely in the formwork and fix it with cable ties or adhesive tape.
5. Fit the ISC Node close to the measuring points outside the formwork in a safe and secure manner.
6. Connect the wires to an analogue multifunction channel of the node.
 - Unscrew the pole terminal until the stripped wire end can be wrapped around the threaded bolt once.
 - Connect the red wire to a brown terminal (+).
 - Connect the black wire to the white terminal (-) of the same channel.
 - Only ever connect one vibration sensor to a pair of terminals or to a channel.
7. Screw the pole terminals back on until they are handtight.
8. Switch on the node. The measured data is received automatically from the connected sensors.
9. Switch on the ISC Hub.
10. Document the node number and channel of each sensor.



It is also advisable to note the fixing locations of the nodes. On an ever changing construction site, it can be difficult to find the units again.



You can find more information in the video of the installation process.

14 PHONO Concrete Detection and Compaction Monitoring

14.3. Checking the functional integrity

Check the functional integrity and data transmission before concreting. By pressing the black button on the node a force connect and upload is initiated, indicated by all LEDs flashing orange and then blue. On the concrete detection screen of the Hub, the status of each vibration sensor is displayed in the form of a four-level traffic light and symbols (Figure 2).

The icons stand for the following detection values:

- Red cloud:** air
- Yellow drop:** water or liquid
- Green wall:** concrete or firm material
- Grey question mark:** error or no signal

The 3 grey/blue dots show compaction level. They will all turn blue when the G-force has been above the set limit for the set time entered in the Hub setting (see page 18). Each blue dot stands for ca. 33 % of the set limit.

Figure 2 shows examples for the results.

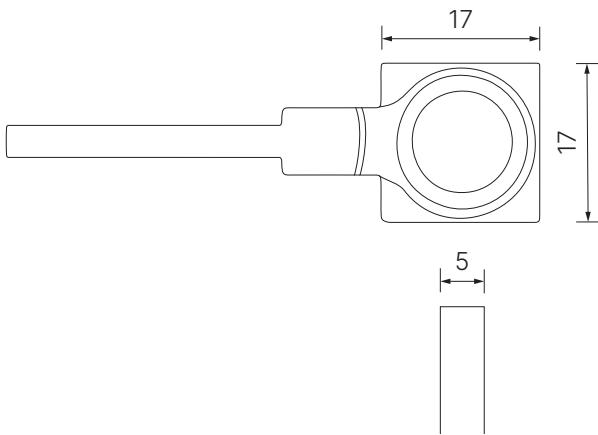

Figure 1: Dimensions of PHONO Sensor
Measurements are displayed in millimeters

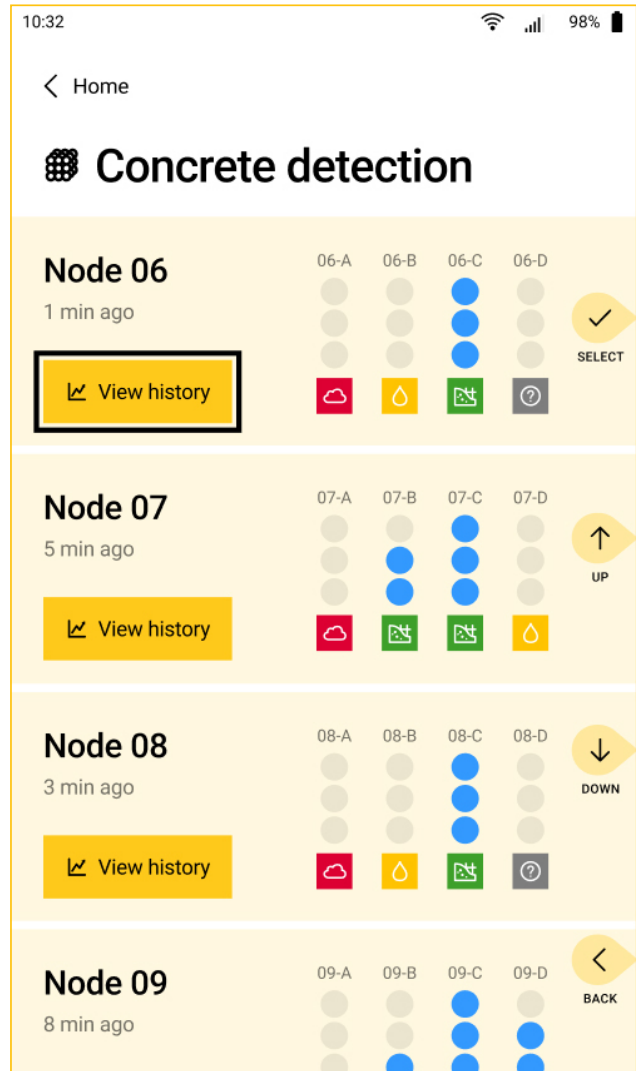

Figure 2: Concrete detection and compaction screen on Hub.

14 PHONO Concrete Detection and Compaction Monitoring

14.4. Deinstallation

1. Switch off the node.
2. Loosen the pole terminals and pull out the wires.
3. Cut the sensor cable flush with the concrete.

Extension cables or sensors that have not been cast into the concrete can be reused. Do not reuse vibration sensors that have been in water for longer than one hour.

Check the cables and sensors for damage and functional integrity before they are used again.

14.5. Cleaning

Remove any water droplets or dust from the sensor head with a soft, damp (not wet) cloth.

- Do not use abrasive or aggressive cleaning agents or solvents (e.g. scouring powder, thinner or gasoline).
- Do not remove stubborn dirt with sharp-edged objects.
- Do not wash the unit under running water or immerse it in water.
- Do not use high-pressure cleaners.

14.6. Maintenance and repairs

The sensor is maintenance-free and intended for one-time use only. Remove defective or damaged sensors and connecting cables from the installation immediately.

14.7. Troubleshooting

Possible causes of unsuccessful testing:

- The sensor is not connected correctly
- The sensor is damaged (broken cable or damaged sound element)
- Node not switched on or low battery
- Data transmission or the WLAN between the hub and the node is disrupted.

The operation of the ISC hub and the node as well as the web application is described in the ISC Hub and Node installation and operating instructions.



Vemaventuri AB

Doktorandgatan 10A
431 44 Mölndal
Sweden

Vemaventuri GmbH

Rudolf-Diesel-Staße 19
89264 Weißenhorn
Germany

Phone: +49 7309 950 2244

Email: info@vemaventuri.io

Website: vemaventuri.io



VEMAVENTURI
A PERI COMPANY