



VEMAVENTURI
A PERI COMPANY

SONO HUB

User Guide v1.1



Language



English 4 – 15



French XX – XX



Spanish XX – XX



German XX – XX

Content

1 Overview **4**

2 Introduction **5**

- 2.1. Intended use 5
- 2.2. Instructions on use 5
- 2.3. Target groups 5

3 Safety Instructions **6**

- 3.1. Warnings 6
- 3.2. General information 6

4 Overview of the Unit **8**

5 Measurement Procedures **9**

- 5.1. Measurement Procedure for Concrete with Low to Medium Slump (F2-F4) 9
- 5.2. For Liquid Concretes with High Slump (F5-F6) 9

6 Adjusting Base Parameters **10**

- 6.1. G-Set adjustment 10
- 6.2. Raw density 11
- 6.3. Recipe characteristic (CHAR) 11
- 6.4. Cement content 11

7 Recycling and Disposal **12**

- 7.1. Disposal 12

8 Potential Issues While Measuring **13**

- 8.1. Dry aggregates 13
- 8.2. Evaporation 13
- 8.3. Air voids and fibers 13
- 8.4. Adjusting SONO for specific concrete mixes 13

9 Storage and Transportation **14**

- 9.1. Storage and transportation 14
- 9.2. Cleaning 14

10 Manufacturing Information **15**

1 Overview

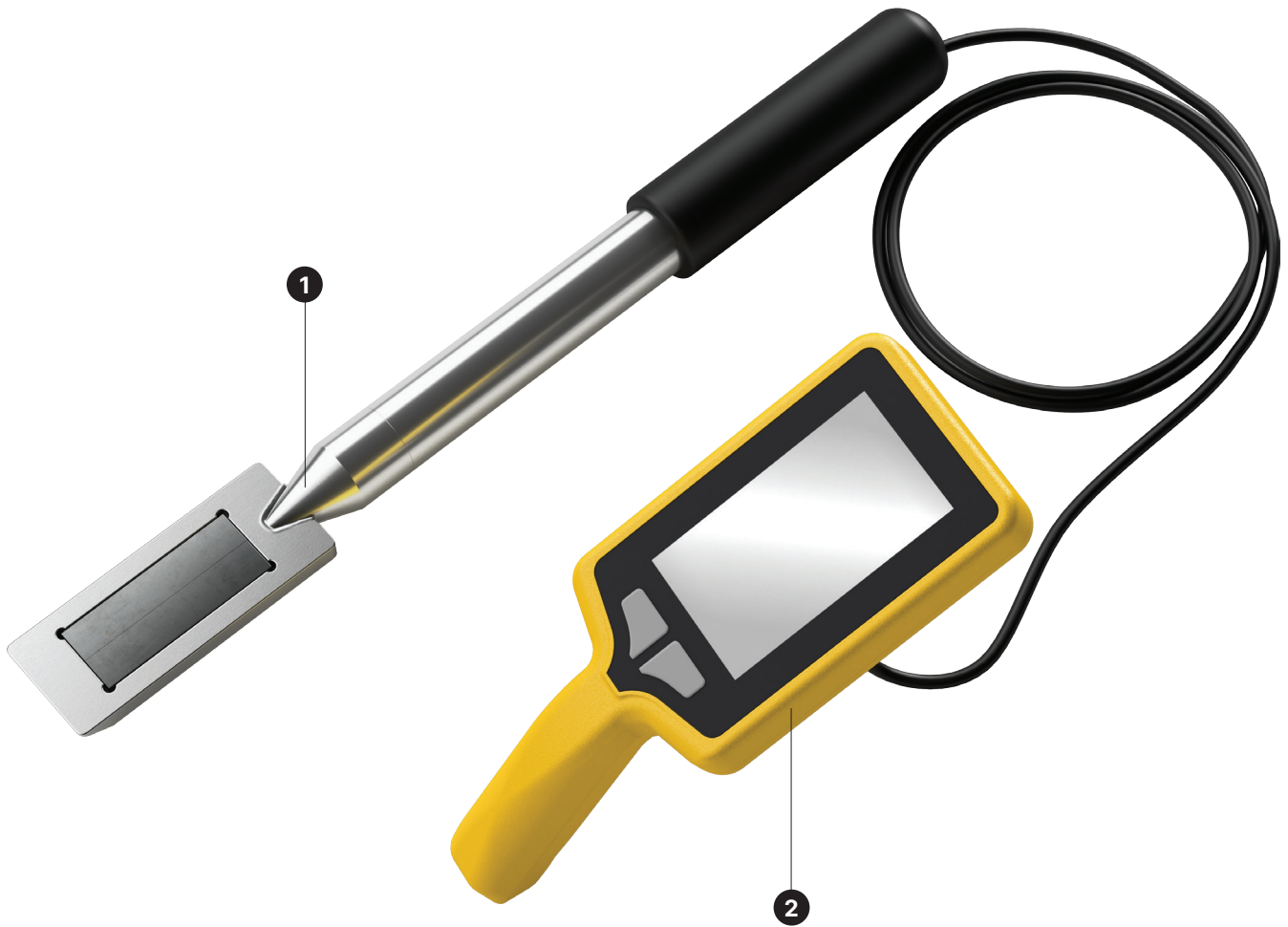

- 1. Measuring probe
- 2. SONO Hub

2 Introduction

2.1. Intended use

Vemaventuri products are designed solely for use in the industrial and commercial sectors by trained personnel.

Only use the product for its specified purpose, while strictly adhering to the provided technical data.

Any use outside the intended purpose is not allowed.

The function and operational safety of the product can only be guaranteed if the generally applicable safety precautions, national regulations, and the specific safety instructions in these Instructions for Use are followed.

The product is intended for measuring purposes as defined and outlined in the technical data. Only the instructions described in the Instructions for Use constitute proper use of the product.

The information regarding the intended use of the system must be observed.

2.2. Instructions on use

Usage that deviates from the intended use as outlined in the Instructions for Assembly and Use constitutes a misapplication with potential safety risks.

Changes to Vemaventuri components are not permitted.

Only original Vemaventuri parts may be used. The use of non-Vemaventuri products or spare parts constitutes misapplication with associated safety risks.

2.3. Target groups

Contractors

These Instructions for Use are intended for contractors who utilize Vemaventuri products for industrial tasks, including measuring or monitoring operations.

Construction site coordinator

The Safety and Health Protection Coordinator is appointed by the client and must:

- Identify potential hazards during the planning phase.
- Determine measures to mitigate risks.
- Create a health and safety plan.
- Coordinate protective measures for contractors and personnel, ensuring they do not endanger each other.
- Monitor compliance with safety measures.

Competent personnel

Competent personnel must possess specialist knowledge gained from professional training, work experience, and recent professional activity, allowing them to understand safety-related issues and carry out inspections properly. Depending on the complexity of the task, varying levels of specialist knowledge may be required.



In other countries, ensure compliance with relevant national guidelines and regulations. If no country-specific regulations are available, it is recommended to follow German guidelines and regulations.

Qualified persons

Vemaventuri products may only be used by personnel who are suitably qualified. These qualified individuals must receive instructions covering at least the following points:

- An understandable explanation of the assembly or dismantling plan for the Vemaventuri product.
- A description of the safety measures for assembling or dismantling the Vemaventuri product.
- Details on safety precautions for changing weather conditions that may impact the product's safety or the personnel.
- Information on permissible loads.

3 Safety Instructions

3.1. Warnings

Warnings appear before instructions for action and are categorised as follows:



Danger

means that serious bodily injury or death will occur if the aforementioned precautions are not taken.



Warning

means that serious bodily injury or death may occur if the aforementioned precautions are not taken.



Caution

means that minor bodily injury may occur if the aforementioned precautions are not taken.



means that damage to property or an undesirable situation may occur if the aforementioned precautions are not taken.

3.2. General information



Warning

If the equipment is used in a manner not specified by the manufacturer or this document, the protection provided by the equipment may be impaired.



Warning

The unit is only for indoor charging with the power adapter and is powered by an internal battery inside the unit when operated in outside environment.



Warning

Do not leave the unit exposed to direct sunlight for an extended period of time.



Safety instructions apply to all service life phases of the system.

The contractor must ensure that the installation and operating instructions provided are available at all times and understood by the site personnel.

3.2.1. Before using the system

- Read and understand this manual and the safety instructions it contains carefully.

- Observe the laws and regulations in force in the country of use. This includes, in particular, safety precautions as required when handling live equipment.
- Check units, mains cables and accessories for damage and functional correctness.
- Damaged connectors and cables must be removed immediately and no longer used.
- Only use original spare parts from the manufacturer.

Failure to observe these safety precautions may result in injury or damage to the unit. The unit has been designed for use in harsh environments. Operations outside of the specified conditions may result in damage to the equipment.

3.2.2. Charging the unit



Danger

Lithium-ion battery is installed in the unit. The battery may only be replaced by a qualified person!

The usage time or the discharge speed of a battery depends on several factors:

- Ambient temperature
- Usage time with the screen ON
- Screen brightness
- Battery age

If the battery capacity and discharge time have decreased significantly, the battery should be replaced. To do this, contact a service workshop designated by the manufacturer.

Never replace the batteries yourself.

The lithium-ion batteries must be charged **before the units are used for the first time**. The battery charging circuitry in the SONO Hub ensures that the batteries do not overheat or get damaged during the charging process.

3.2.3. Charging the SONO Hub



Danger

When charging the unit, only use the charger specified by the manufacturer or a comparable voltage source. A deviation in the charging voltage can result in damage to the device.

The device heats up during the charging process. If the SONO Hub only functions briefly or not at all despite repeated charging, the built-in battery is defective and must be replaced. Please contact Vemaventuri if this is the case.

3 Safety Instructions

3.2.4. Temperatures and ambient conditions

The SONO Hub has been designed for use in harsh environments. Operations outside of the specified conditions may result in damage to the equipment.

Electrical characteristics	
Input	5 V DC max, 3 A
Rated capacity	Up to 17.28 Wh
Rated Voltage	3,6 VDC
Probe input	12 VDC
Number of cells	1
Display	4,3" with capacitive touch capabilities
Interface	1x 7pin socket 1x USB-c

Ambient conditions	
Operating temperature (discharging)	-5 to 45 °C (23 to 113°F)
Ambient temperature when charging the battery	5 to 40 °C (41 to 104 °F)
Transport temperature	15 to 25 °C (59 to 77 °F)
Storage temperature	15 to 25 °C (59 to 77 °F)
Ambient humidity	90 % rH non-condensing

Housing material	Plastic
Protection type	IP66 pursuant to EN 60529
Weight	0,35 kg
Over voltage category	OVC I
Degree of pollution	3
Usage	indoor and outdoor up to 2000 m a.s.l.
Can also be used in wet locations Definition of wet locations: The environment in which water or another conductive liquid may be present and in which it is likely that the resistance of the human body will be reduced by wetting of the contact between the human body and the device and by wetting of the contact between the human body and its environment.	

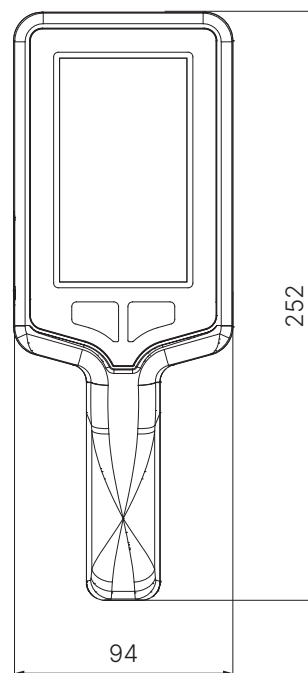
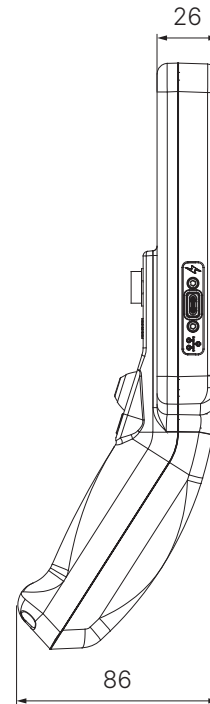
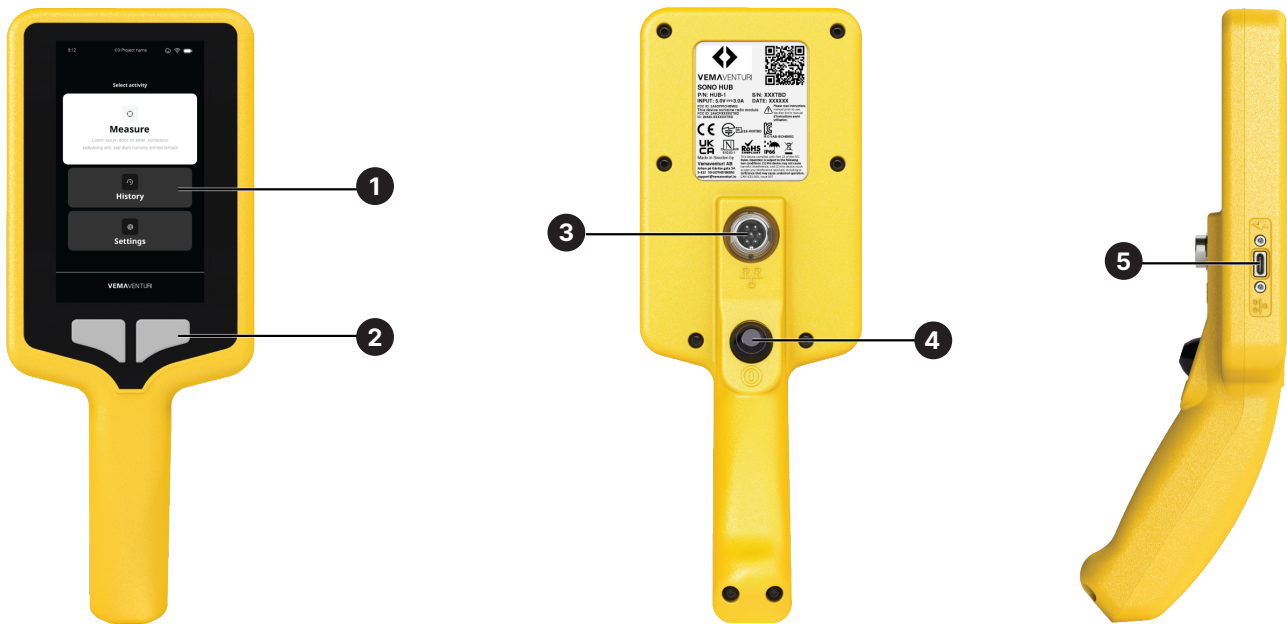

Figure 1: Measurements are displayed in millimeters

4 Overview of the Unit



1. 4,3" touchscreen for navigating and operating the unit.
2. Function buttons, used to navigate the options displayed on the screen.
3. 7-pin M12 connector to connect the measurement probe to the unit.
4. Trigger button to select option on screen, and to take measurement from the probe.
5. USB-C port for charging the unit and extracting data from the internal memory.

5 Measurement Procedures

5.1. Measurement Procedure for Concrete with Low to Medium Slump (F2-F4)

1. Connect the measuring probe to the 7-pin M12 connector on the backside of the SONO Hub.
2. Ensure concrete is well-mixed.
3. Press and hold the black trigger button on the back of the device for a few seconds until the screen turns on and the hub starts up.
4. Adjust the parameters manually or choose a preset (see Chapter 5 for details).
5. Insert probe at an angle near the edge of a 10-12 liter plastic bucket.
6. Compress concrete by tapping the bucket. (Figure 1)
7. Start measurement by pressing the trigger button at the backside of the SONO Hub. Shift probe position for each additional measurement.
8. Repeat the process until you have completed five individual measurements at five different points around the inside of the bucket.

Tip: Avoid moving the probe during measurements.

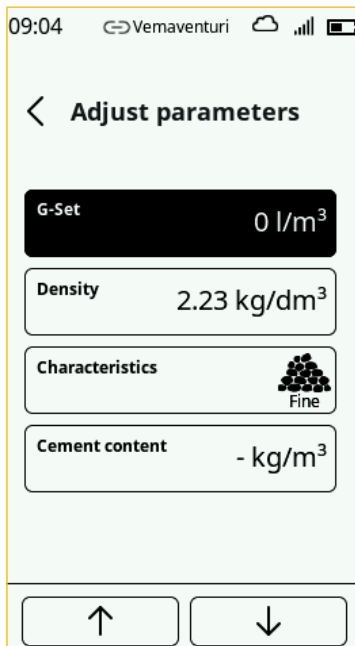

Figure 1: Suggested measuring points

5.2. For Liquid Concretes with High Slump (F5-F6)

1. Follow the same process, but fill the bucket to $\frac{3}{4}$ volume.
2. Use a plastic shovel to keep gravel near the probe. Press the probe diagonally into the concrete.

6 Adjusting Base Parameters



To display the water content as a Darr value with an accuracy of ± 1 to ± 3 liters per m^3 , SONO Hub must be set up for a specific concrete formulation and rock type. This is done by adjusting the recipe characteristic (CHAR), Raw Density and G-set Parameters.

From the main menu, select “Measure” to access the measurement setup:

- Adjust parameters: Define the measurement parameters needed for your material or project.
- Load preset: If you have saved presets from previous measurements, you can select one here. If this is your first measurement, no presets will be available yet, in this case, set your parameters manually and save them as a new preset for future use.
- Save preset: After configuring all parameters, you can save your setup by selecting “Save preset.”

6.1. G-Set adjustment

A correctly adjusted G-Set value significantly improves accuracy, especially for special concrete types (e.g., fiber-reinforced mixes).

The SONO Hub measures the free water in fresh concrete as well as part of the core (suction) water. Different aggregate types absorb water differently: some rock types take up very little, while others, such as sandstone or lime grit, can absorb up to 50 liters of core water per cubic meter. Since this core water does

not contribute to cement bonding, it is not included in the water/concrete ratio.

Similar to the Darr method, SONO Hub detects three types of water:

- **Free Water**
This is the water that contributes to the water/cement ratio.
- **Core Water**
Part of the water absorbed by the aggregates. SONO Hub measures roughly one-third of this core water. The remaining portion (approximately two-thirds) is represented and corrected via the G-Set parameter.
Example: If the core water is $15 L/m^3$, the corresponding G-Set value is about $-10 L/m^3$. This value is automatically subtracted so that the displayed value reflects the effective water content.
- **Additives**
Additives that behave like water are also detected and must be considered.

6.1.1. The G-Set parameter

The G-Set compensates for the portion of core water that the radar signal detects, even though SONO Hub should primarily measure the free water available for cement hydration.

Because different aggregates and concrete formulations contain varying amounts of core water, a unique G-Set value is required for each mix to display the correct (Darr-equivalent) water content.

If SONO Hub displays a water content that is too high, the G-Set must be adjusted by the corresponding number of liters.

6.1.2. How to determine the correct G-Set:

Fresh concrete is not an easy to measure material. The correct use of SONO Hub requires careful compliance of the instructions detailed in this document. Even with the correct base parameters, some concrete mixes (depending on rock types) may require a G-Set adjustment. This can be verified by comparing SONO Hub readings with:

1. Using comparative measurements with SONO Hub on concrete samples with known water contents (e.g., using dried aggregates).
2. Using comparative measurements with known Darr values. Note that the Darr method has its own sources of error.

6 Adjusting Base Parameters

6.1.3. G-Set Parameter specifications

- Adjustable range: $\pm 50 \text{ L/m}^3$
- Step size: 1 L/m^3
- Typical starting value: -10 L/m^3
- Confirm the input using the trigger button.



Darr Water Content Equation:

Darr value = effective amount of water + core water + additives that behave like water

6.2. Raw density

Density influences the calculation of water content. You can enter:

the bulk density, the density from a splitter test, or the design density from the mix calculation.

Even small differences in density have a noticeable impact: A density deviation of $\pm 0.02 \text{ g/cm}^3$ corresponds to approx. $\pm 1.6 \text{ L}$ of water.

When the exact density cannot be measured on-site, using the design density is an acceptable compromise.

The Density is adjustable in 0.001 g/cm^3 steps.

6.3. Recipe characteristic (CHAR)

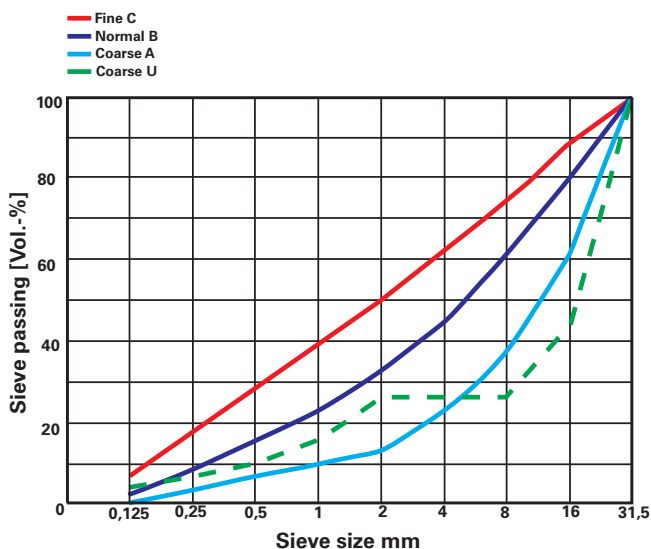

The characteristics (CHAR) parameter adjusts the measurement according to the aggregate grading.

Different grading curves influence how the radar signal interacts with the material, and SONO Hub compensates for these effects.

SONO Hub offers four grading curve options, each representing a characteristic concrete formulation:

• Fine (Grading Curve C)

SONO Hub measures too little water and corrects the water content slightly upward. This applies to concrete with high mortar content (lots of sand and fine material), high cement content, standard additives, standard admixtures, and PCEs.

• Normal (Grading Curve B)

No or only slight corrections are needed. This is used for continuous, well-distributed grading curves with standard additives, admixtures, and PCEs.

• Coarse (Grading Curve A)

SONO Hub measures too much water and corrects the water content slightly downward.

1. Applies to concrete with higher k-values and low mortar content.
2. Also applies when using a continuous B-grading curve with low target water content (less than 160 l/m^3) and a high amount of PCE high-performance superplasticiser for flowability.

• Special (Grading Curve U)

SONO Hub measures too much water and corrects downward. This is for gap grading (little or no 2/8 or 4/8 gravel) with standard additives, admixtures, and PCEs.

Choose the Characteristics / CHAR option that best matches your concrete formulation to achieve the highest measurement accuracy.

6.4. Cement content

Enter the cement content in kg/m^3 of your mix to enable direct calculation of the w/c-ratio. You can also define a limit value, measurements exceeding this limit will be flagged automatically.

7 Recycling and Disposal

7.1. Disposal



The units must be disposed of and recycled in accordance with local environmental protection regulations.

- Do not dispose of electronic components with household waste.
- In the European Union, comply with Directive 2012/19/ EU on Waste Electrical and Electronic Equipment (WEEE)

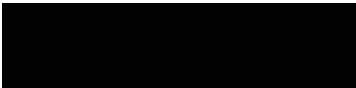
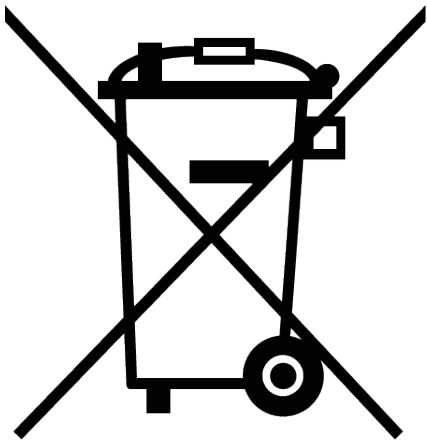

8 Potential Issues While Measuring

8.1. Dry aggregates

When using very dry aggregates, wait before measuring with SONO Hub. The water content might appear too high because aggregates may take 10-20 minutes to fully saturate, depending on the rock type.

8.2. Evaporation

In small, open mixers, water can evaporate quickly. Adding more water afterward (e.g., +50 grams) to adjust the content from 175 to 185 liters/m³ can result in significant deviations. Depending on the mixing time, up to a 5 liter/m³ measurement error may occur due to evaporation.

8.3. Air voids and fibers

- Air voids and glass fibers reduce the concrete's density. SONO Hub does not detect air voids or glass fibers, meaning the water content displayed may be 5-10 liters/m³ too high.
- For concrete with air voids, glass, or steel fibers, adjust the G-set by -5 to -10 liters/m³ to account for the excess reading.

8.4. Adjusting SONO for specific concrete mixes

It is recommended to adjust SONO Hub for the specific concrete recipe, considering the type and origin of the aggregates.

If SONO Hub shows a water content that is too high for a particular concrete, you will need to adjust the G-set parameter. The correct G-set value can be determined in two ways:

- **Comparative measurements:**
Use concrete mixed with dried aggregates where the water content is known.
- **Kiln-Dried comparisons:**
Compare SONO Hub measurements with water content values obtained from kiln drying.

9 Storage and Transportation

9.1. Storage and transportation

Store and transport the unit in a way that prevents unintentional movements or potential damage.

Do not drop the unit.

Use original Vemaventuri storage and transport systems whenever possible.

Protect the unit from exposure to the weather, oils, and aggressive substances that could affect safety.

9.2. Cleaning

- Do not use aggressive chemical agents or abrasives when cleaning.
- Avoid using hard sponges.
- Repairs must only be performed by the manufacturer.
- Only original components may be used for repairs.

10 Manufacturing Information

Designed and manufactured by

Vemaventuri AB
Doktorandgatan 10A
431 44 Mölndal
Sweden

Assembled at

BEPE Elektronik AB
Borgens gata 8A
441 39 Alingsås

Vemaventuri AB

Doktorandgatan 10A
431 44 Mölndal
Sweden

Vemaventuri GmbH

Rudolf-Diesel-Staße 19
89264 Weißenhorn
Germany

Phone: +49 7309 950 2244

Email: info@vemaventuri.io

Website: vemaventuri.io



VEMAVENTURI
A PERI COMPANY