



VEMAVENTURI
A PERI COMPANY

TEMO LINK

Concrete Temperature and Maturity Monitoring

User Guide v1.1

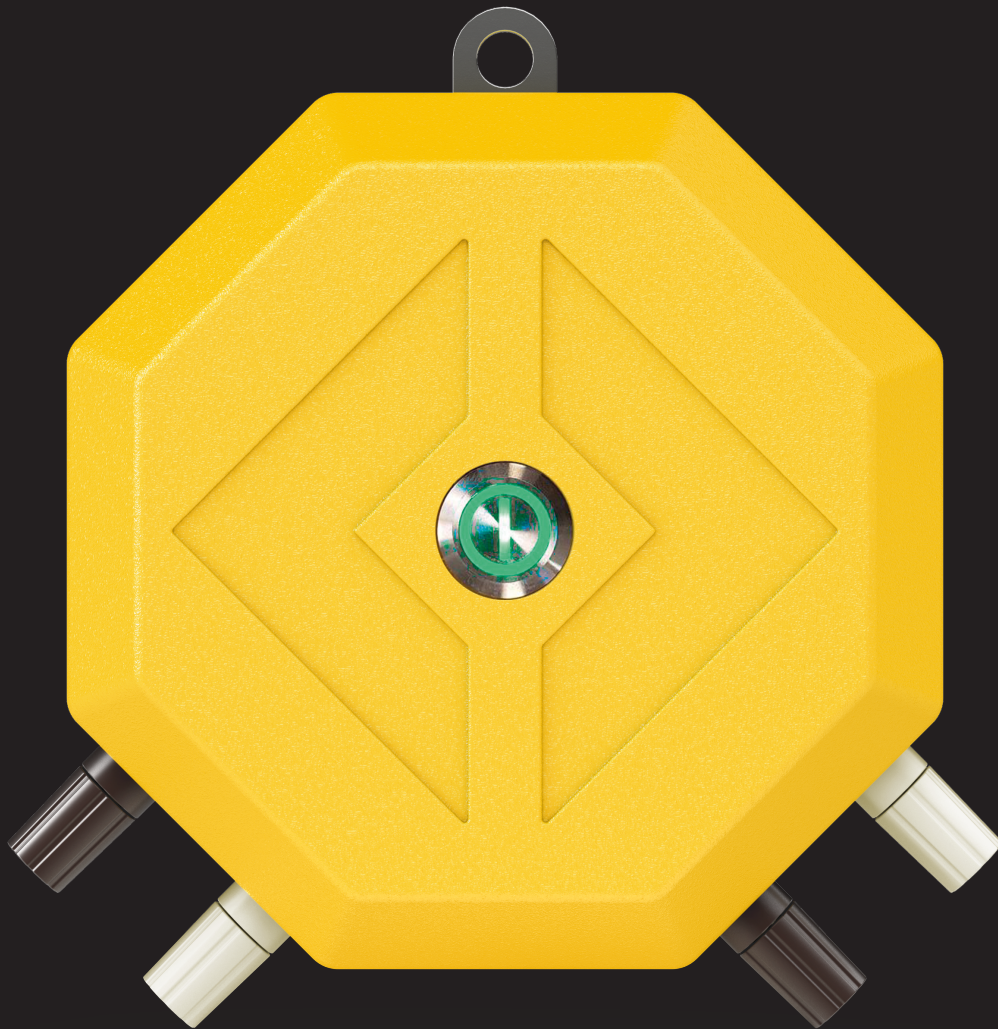

Language



English 4 – 13



French XX – XX



Spanish XX – XX



German XX – XX

Content

| | | |
|----------|---|-----------|
| 1 | Overview | 4 |
| 2 | Introduction | 5 |
| 2.1. | Intended use | 5 |
| 2.2. | Instructions on use | 5 |
| 2.3. | Target groups | 5 |
| 3 | Safety Instructions | 6 |
| 3.1. | Warnings | 6 |
| 3.2. | General information | 6 |
| 4 | Application | 8 |
| 4.1. | Calibration for Concrete Maturity Monitoring | 8 |
| 4.2. | Connect device to project | 9 |
| 4.3. | Connecting and using the TEMO Link | 10 |
| 5 | Connectivity and Upload Process | 11 |
| 6 | LED Indications | 12 |
| 7 | Recycling and Disposal | 13 |
| 7.1. | Disposal | 13 |
| 8 | Manufacturing Information | 14 |

1 Overview

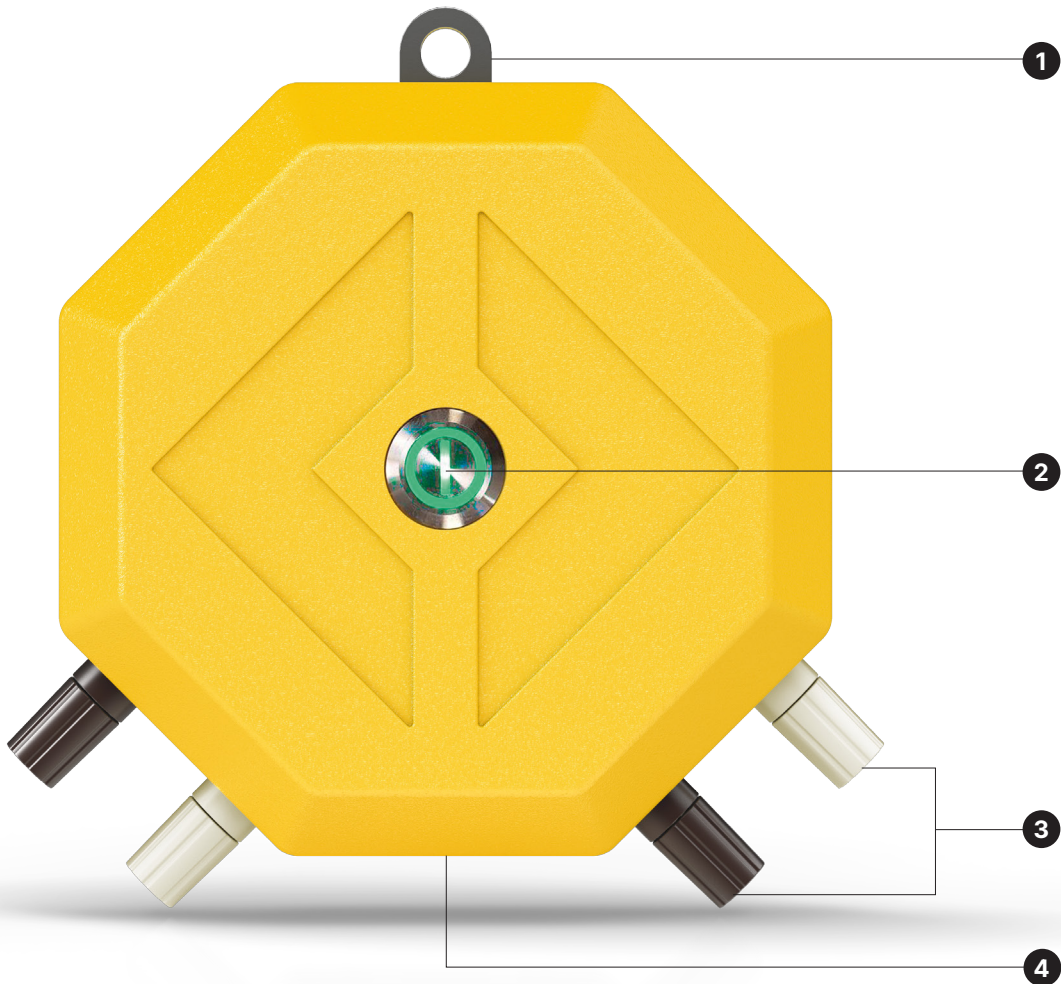

1. Hanging bracket
2. ON/OFF button with status LED
3. Measuring channels
4. USB-C for charging and data transfer

2 Introduction

2.1. Intended use

Vemaventuri products are designed solely for use in the industrial and commercial sectors by trained personnel.

Only use the product for its specified purpose, while strictly adhering to the provided technical data.

Any use outside the intended purpose is not allowed.

The function and operational safety of the product can only be guaranteed if the generally applicable safety precautions, national regulations, and the specific safety instructions in these Instructions for Use are followed.

The product is intended for measuring purposes as defined and outlined in the technical data. Only the instructions described in the Instructions for Use constitute proper use of the product.

The information regarding the intended use of the system must be observed.

2.2. Instructions on use

Usage that deviates from the intended use as outlined in the Instructions for Assembly and Use constitutes a misapplication with potential safety risks.

Changes to Vemaventuri components are not permitted.

Only original Vemaventuri parts may be used. The use of non-Vemaventuri products or spare parts constitutes misapplication with associated safety risks.

2.3. Target groups

Contractors

Contractors working in industrial or commercial environments, particularly those involved in concrete placement, monitoring, or quality control tasks.

Concrete testing laboratories

Laboratories performing quality testing or evaluating curing conditions using measurement and monitoring equipment.

Quality assurance and site engineers

Personnel responsible for monitoring concrete performance, compliance, and curing conditions on construction sites.

Concrete suppliers

Personnel involved in the delivery and handling of fresh concrete, particularly when verifying mix conditions or supporting production control.

Construction site coordinator

The Safety and Health Protection Coordinator is appointed by the client and must:

- Identify potential hazards during the planning phase.
- Determine measures to mitigate risks.
- Create a health and safety plan.
- Coordinate protective measures for contractors and personnel, ensuring they do not endanger each other.
- Monitor compliance with safety measures.

Competent personnel

Competent personnel must possess specialist knowledge gained from professional training, work experience, and recent professional activity, allowing them to understand safety-related issues and carry out inspections properly. Depending on the complexity of the task, varying levels of specialist knowledge may be required.



In other countries, ensure compliance with relevant national guidelines and regulations. If no country-specific regulations are available, it is recommended to follow German guidelines and regulations.

Qualified persons

Vemaventuri products may only be used by personnel who are suitably qualified. These qualified individuals must receive instructions covering at least the following points:

- An understandable explanation of the assembly or dismantling plan for the Vemaventuri product.
- A description of the safety measures for assembling or dismantling the Vemaventuri product.
- Details on safety precautions for changing weather conditions that may impact the product's safety or the personnel.
- Information on permissible loads.

3 Safety Instructions

3.1. Warnings

Warnings appear before instructions for action and are categorised as follows:



Danger

means that serious bodily injury or death will occur if the aforementioned precautions are not taken.



Warning

means that serious bodily injury or death may occur if the aforementioned precautions are not taken.



Caution

means that minor bodily injury may occur if the aforementioned precautions are not taken.



means that damage to property or an undesirable situation may occur if the aforementioned precautions are not taken.

3.2. General information



Warning

If the equipment is used in a manner not specified by the manufacturer or this document, the protection provided by the equipment may be impaired.



Warning

The unit is only for indoor charging with the power adapter and is powered by an internal battery inside the unit when operated in outside environment.



Warning

Do not leave the unit exposed to direct sunlight for an extended period of time.



Safety instructions apply to all service life phases of the system.

The contractor must ensure that the installation and operating instructions provided are available at all times and understood by the site personnel.

3.2.1. Before using the system

- Read and understand this manual and the safety instructions it contains carefully.

- Observe the laws and regulations in force in the country of use. This includes, in particular, safety precautions as required when handling live equipment.
- Check units, mains cables and accessories for damage and functional correctness.
- Damaged connectors and cables must be removed immediately and no longer used.
- Only use original spare parts from the manufacturer.

Failure to observe these safety precautions may result in injury or damage to the unit.

The unit has been designed for use in harsh environments. Operations outside of the specified conditions may result in damage to the equipment.

3.2.2. Charging the unit



Danger

Lithium-ion battery is installed in the unit. The battery may only be replaced by a qualified person!

The usage time or the discharge speed of a battery depends on several factors:

- Ambient temperature
- Usage time
- Temperature log rate
- Battery age

If the battery capacity and discharge time have decreased significantly, the battery should be replaced. To do this, contact a service workshop designated by the manufacturer.

Never replace the batteries yourself.

If the unit is left unused, the battery will discharge over approximately three months. After being stored without charge for this period, the unit may be unresponsive for up to 10 minutes when first connected to power. To maintain battery health, the unit should be charged at least every six months, even when not in use.

The lithium-ion batteries must be charged **before the units are used for the first time**. The battery charging circuitry in the TEMO Link ensures that the batteries do not overheat or get damaged during the charging process.

3 Safety Instructions

3.2.3. Charging the TEMO Link



Danger

When charging the unit, only use the charger specified by the manufacturer or a comparable voltage source. A deviation in the charging voltage can result in damage to the device.

The device heats up during the charging process. If the TEMO Link only functions briefly or not at all despite repeated charging, the built-in battery is defective and must be replaced.

3.2.4. Temperatures and ambient conditions

TEMO Link has been designed for use in harsh environments. Operations outside of the specified conditions may result in damage to the equipment.

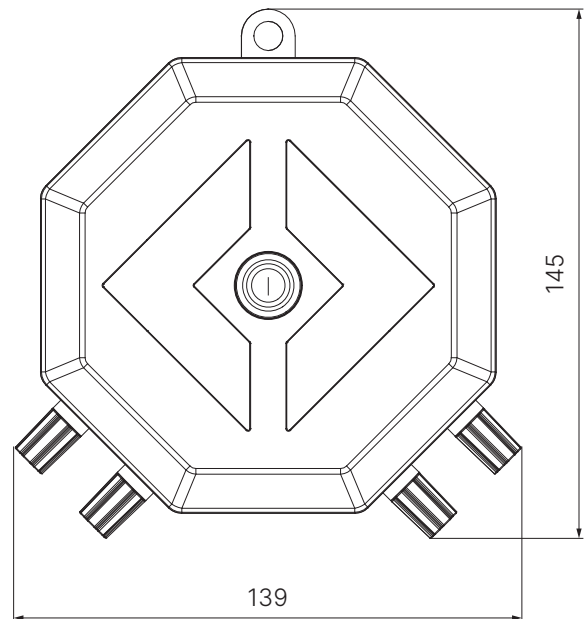

| Electrical characteristics | |
|----------------------------|-----------------|
| Input | 5 V DC max, 3 A |
| Rated capacity | Up to 17.28 Wh |
| Rated Voltage | 3,6 VDC |
| Number of cells | 1 |
| Interface | 1x USB-C |

| Ambient conditions | |
|---|-----------------------------|
| Operating temperature (discharging) | -5 to 45 °C (23 to 113°F) |
| Ambient temperature when charging the battery | -20 to 50 °C (-4 to 122 °F) |
| Transport temperature | 15 to 25 °C (59 to 77 °F) |
| Storage temperature | 15 to 25 °C (59 to 77 °F) |
| Ambient humidity | 90 % rH non-condensing |

| Housing material | Plastic |
|-----------------------|--|
| Protection type | IP66 (EN 60529) * |
| Weight | 0,4 kg |
| Over voltage category | OVC I |
| Degree of pollution | 3 |
| Usage | indoor and outdoor up to 2000 m a.s.l. |

Can also be used in wet locations
 Definition of wet locations:
 The environment in which water or another conductive liquid may be present and in which it is likely that the resistance of the human body will be reduced by wetting of the contact between the human body and the device and by wetting of the contact between the human body and its environment.

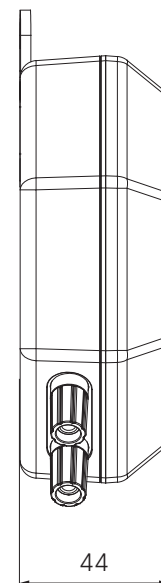

Figure 1: Measurements are displayed in millimeters

4 Application

TEMO Link is a compact and easy-to-use tool for monitoring concrete temperature and maturity. It comes with just two parts—a measurement unit and a type-T thermocouple cable. The cable connects to the measuring channels and is reusable, except for the section embedded in the concrete. TEMO Link records temperature data during the curing process and uploads it to Vemaventuris WebApp. This real-time data helps you track the curing progress and make informed, data-driven decisions. Its simple design minimizes setup time and maintenance, ensuring a smooth monitoring experience for your construction projects.

4.1. Calibration for Concrete Maturity Monitoring

This section describes the end-to-end procedure to calibrate a concrete mix for maturity-based, real-time strength estimation. Follow these steps before using in-place maturity results to make decisions such as striking formwork, removing cold-weather protection, or opening to traffic. Requirements and actions below align with common industry practice (e.g., ASTM C 1074, DIN EN 12390-2) for specimen preparation and curing.

4.1.1. Preparation

Plan for a minimum duration of 28 days or until the design strength is reached. Use the same concrete mix intended for the structure and prepare between five and fifteen cubes or cylinders according to your local standards. Label each specimen with its casting date. Install a Vemaventuri temperature sensor, in the center of at least one specimen, ideally the last one scheduled for crushing. Cure all specimens according to local standards, such as a 20 °C water bath in compliance with DIN EN 12390-2.

4.1.2. Crushing Schedule and Data Capture

Carry out compressive strength tests at 1, 2, 3, 7, and 28 days. If early decisions are anticipated, include additional intervals during the first few days. For each specimen, record the exact crushing time and the measured compressive strength in megapascals.



Increasing the number of specimens improves the accuracy of the calibration curve by reducing variance. If speed is critical, plan additional early-age tests to refine the strength trajectory for early decision-making.

4.1.3. Create the Concrete Calibration

In the WebApp navigate to Menu → Concrete → Concrete Calibration and select “Create New Concrete Calibration.” Enter the required details, including basic information, concrete data, and the temperature channels linked to the embedded sensor.

4.1.4. Maturity-Strength Calibration Output

Once all data is entered, the WebApp will generate a maturity–strength curve based on recognized methods such as Saul or Arrhenius, as referenced in e.g. ASTM C1074. This curve enables estimation of in-place strength using sensor temperature data collected on site. (Figure 1)

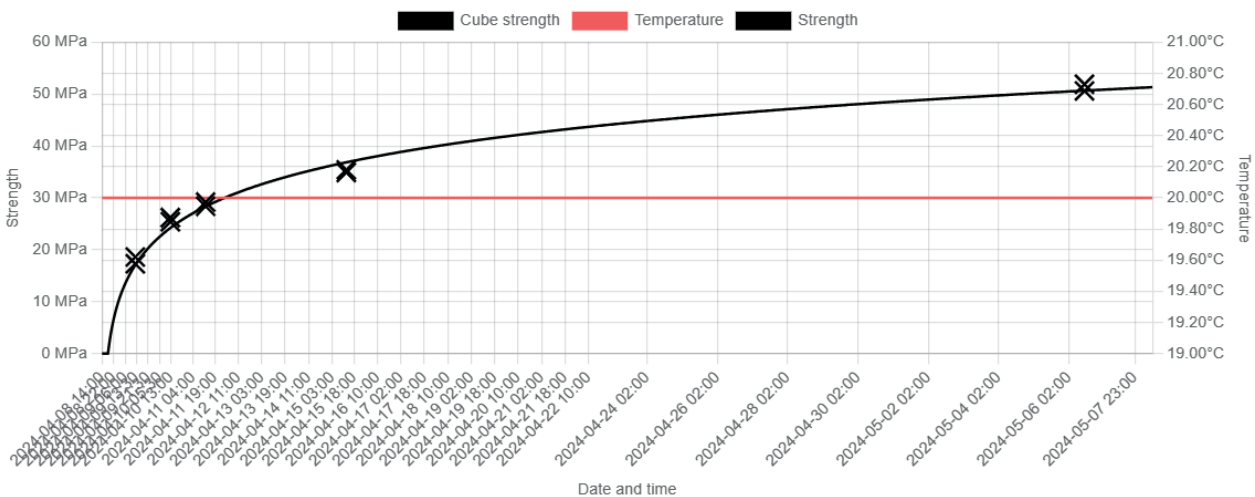

Figure 1: Calibration

4 Application

4.2. Connect device to project

With the project and dashboard set up, the next step will be to connect devices to your project. Click on "Devices". Under "Connect new unit" select the type of device you want to connect and follow the process.

Steps to connect a TEMO Link

1. Turn on TEMO Link by pressing and holding the ON/OFF button for three seconds.
2. Device establishes a cloud connection after booting.
3. Device LED blinks green.
4. Scan the QR code on the backside of the device.
5. Log in to or create an account on <https://insite.peri.app/>
5. Follow the instructions on screen to be guided through the connection process.

Note:

If the device has been connected to a previous project:

1. Turn on the device.
2. Press the ON/OFF button once.
3. Wait until the green LED turns on.
4. Quickly press the button 4 more times to make the LED blink green.

4.2.1. Updating TEMO Link

To initiate an update to the device:

1. Go to the device overview on <https://insite.peri.app>
2. Select the device
3. Click the "update device" button

If an update is available, the device will:

- Upload all stored data.
- Automatically install the update.

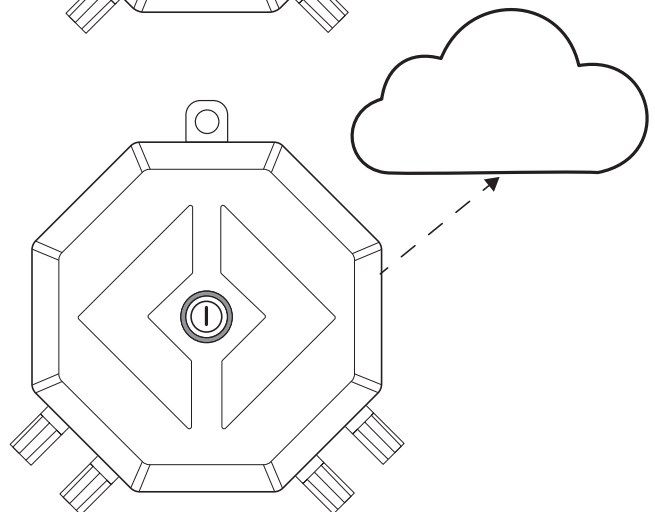
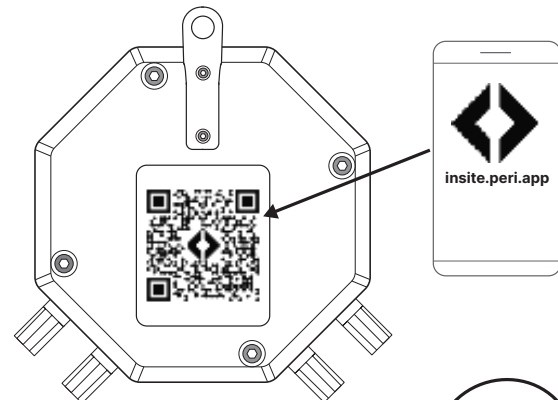
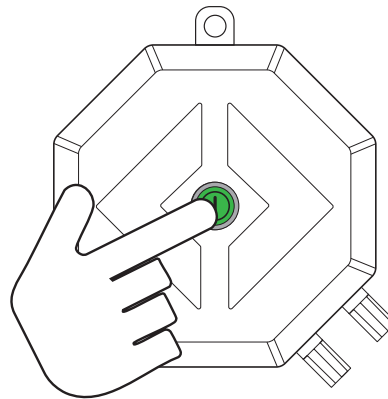

4 Application

4.3. Connecting and using the TEMO Link



Risk of incorrect measurements or damage to the thermocouple!

- Do not use binding wire, nails or staples to fasten the thermocouple.
- Only establish or release connections when the device is switched off.
- Only the thermocouple supplied and approved by the manufacturer may be used
- Do not extend the thermocouple with other cables or wires.

4.3.1. Preparation, attaching and connecting up the thermocouple

- Check the thermocouple cable for any visible damage.
 - Have your choice of cable ties and adhesive tape to hand.
1. Find a suitable position inside the formwork that will be completely filled with concrete to use as the measuring point.
 2. Strip the insulation from the thermocouple at the measuring point in the formwork by at least 15 mm and twist the wires together. The thermocouple only becomes functional when the wire ends make conductive contact. (Figure 1)
 3. Protect the twisted measuring end with a shrink sleeve or insulating tape. (Figure 2)
 4. Position the thermocouple safely in the formwork and fix it with cable ties or adhesive tape.
 5. Cut the thermocouple cable to length up to the Node and route it over or through the formwork.
 6. Split or strip the end of the cable with a knife and strip the insulation from the wires by at least 12 mm. (Figure 3)
 7. Connect the wires to a measuring channel on the device. (Figure 4)
 - Unscrew the pole terminal until the stripped wire end can be wrapped around the threaded bolt once.
 - Connect the brown wire to a brown terminal (+).
 - Connect the white wire to the white terminal (-) of the same channel.
 - Only ever connect one thermocouple to a channel.
 8. Screw the pole terminals back on until they are handtight.

9. Switch on the device. The measured data is received automatically from the connected sensors.
10. – When measuring the core temperature and nearsurface temperature in a concrete body, document the exact position of each sensor.
 - If the temperature in cooling or heating lines is measured, document which thermocouple is attached to the input line and which to the output line.



Figure 1: Measuring point



Figure 2: Measuring point with shrink sleeve



Figure 3: Cable end at the measuring channel

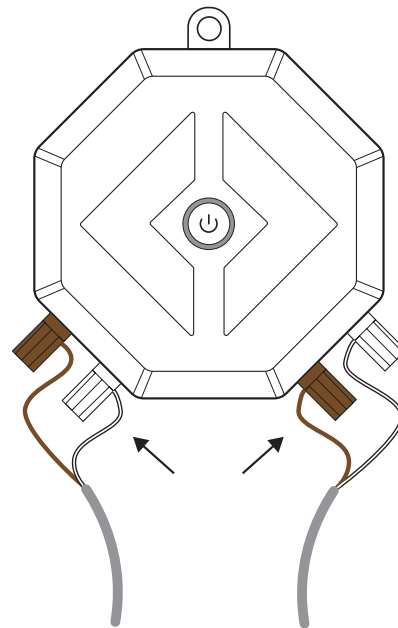

Figure 4: Connection to device

5 Connectivity and Upload Process

TEMO Link connects to the Cloud via LTE to upload data.

- It wakes up every 15 minutes to log a temperature measurement.
- It attempts to upload these logged measurements every hour.

If Cloud connection fails:

- TEMO Link will continue logging locally.
- To save battery, it will not keep trying to connect.
- Instead, it will wait 12 hours (rounded down) before trying again.







If you press the button to force-synchronize the device





- TEMO Link will try to connect for up to 5 minutes.
- If this fails, it will wait 12 hours before trying again (unless another force connect is triggered).
- If the upload is successful, TEMO Link will return to the 1-hour upload schedule.

This behavior prevents unnecessary battery drain during Cloud outages or poor coverage (e.g. in tunnels).

6 LED Indications

TEMO Link uses a single button with an LED indicator to show its status. The table below explains what the unit is doing.

| LED Behaviour | | Event |
|---|----------------|---|
|  | steady green | Device is powered on and connected to a project |
|  | Flashing green | Device is in connection mode and is waiting to connect to a project |
|  | Pulsing green | Charger is connected and unit is charging, When fully charged LED will be steady green |
|  | Flashing green | New firmware is being downloaded (after initiated on the WebApp) |
|  | Flashing red | Firmware update has failed |
|  | No light | Device is in sleep mode Device is powered off (press button once to see if it wakes up or is powered off) |

| Action | LED Behaviour | Event |
|---|---|---|
| Press and hold button (When device is powered OFF) |  | Light fades up green Device is powered ON, connects to cloud |
| Press button once |  | Light turns on briefly, then off again Wakes device from sleep, force connects to cloud and uploads data |
| Press 3 times quickly (When device is powered ON) |  | Flashing green Device enters connection mode and can be connected to a project |
| Press and hold button (When device is powered ON) |  | Light fades down green Device is powered OFF |

7 Recycling and Disposal

7.1. Disposal



The units must be disposed of and recycled in accordance with local environmental protection regulations.

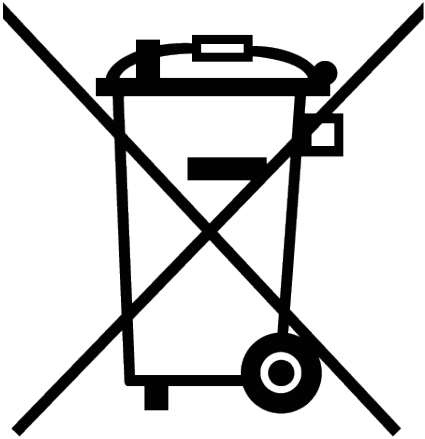

Designed and manufactured by

Vemaventuri AB
Doktorandgatan 10A
431 44 Mölndal
Sweden

Assembled at

BEPE Elektronik AB
Borgens gata 8A
441 39 Alingsås



Vemaventuri AB

Doktorandgatan 10A
431 44 Mölndal
Sweden

Vemaventuri GmbH

Rudolf-Diesel-Staße 19
89264 Weißenhorn
Germany

Phone: +49 7309 950 2244

Email: info@vemaventuri.io

Website: vemaventuri.io



VEMAVENTURI
A PERI COMPANY